

JVC

SCHEMATIC DIAGRAMS

TV/DVD COMBO

AV-20FD22

CD-ROM No.SML200104

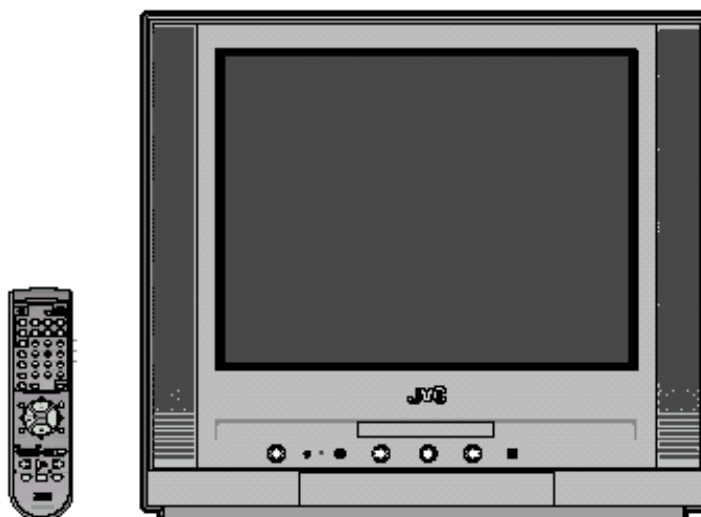

AV-20FD22 STANDARD CIRCUIT DIAGRAM

NOTE ON USING CIRCUIT DIAGRAMS

1.SAFETY

The Components identified by the symbol Δ are critical for safety. For continued safety, replace safety critical components only with manufacturer's recommended parts.

2.INDICATION OF PARTS SYMBOL [EXAMPLE]

●In the PC board :R1209→R209

3.NOTE FOR REPAIRING SERVICE

This model's power circuit is partly different in the GND.

Please, care must be taken for the following points.

(1)Do not touch the LIVE side GND or the LIVE side GND and the ISOLATED(NEUTRAL) side GND simultaneously. If the above caution is not respected, an electric shock may be caused. Therefore, make sure that the power cord is surely removed from the receptacle when, for example, the chassis is pulled out.

(2)Do not short between the LIVE side GND and ISOLATED(NEUTRAL) side GND or never measure with a measuring apparatus (oscilloscope, etc.) the LIVE side GND and ISOLATED(NEUTRAL) side GND at the same time. If the above precaution is not respected , a fuse or any parts will be broken.

◇ Since the circuit diagram is a standard one, the circuit and circuit constants may be subject to change for improvement without any notice.

CONTENTS

SEMICONDUCTOR BASE CONNECTIONS	2
BLOCK DIAGRAMS	3
TV BLOCK DIAGRAM	
DVD BLOCK DIAGRAM	
POWER BLOCK DIAGRAM	
CONNECTION DIAGRAM	9
CIRCUIT DIAGRAMS	11
SYSCON PCB MPEG SCHEMATIC DIAGRAM	
SYSCON PCB SDRAM SCHEMATIC DIAGRAM	
SYSCON PCB SYSCON SCHEMATIC DIAGRAM	
SYSCON PCB VIDEO ENCODER SCHEMATIC DIAGRAM	
AV PCB POWER SCHEMATIC DIAGRAM	
AV PCB MICON/TUNER SCHEMATIC DIAGRAM	
AV PCB VIF/SIF/CHROMA SCHEMATIC DIAGRAM	
AV PCB SOUND AMP SCHEMATIC DIAGRAM	
AV PCB I/O SCHEMATIC DIAGRAM	
AV PCB AV SW SCHEMATIC DIAGRAM	
AV PCB COMB FILTER SCHEMATIC DIAGRAM	
AV PCB STEREO SCHEMATIC DIAGRAM	
OPERATION PCB SCHEMATIC DIAGRAM	
MAIN PCB TV POWER SCHEMATIC DIAGRAM	
MAIN PCB DEFLECTION SCHEMATIC DIAGRAM	
CRT PCB SCHEMATIC DIAGRAM	
PATTERN DIAGRAMS	43
SYSCON PCB PATTERN	
AV PCB PATTERN	
OPERATION PCB PATTERN	
MAIN/CRT PCB PATTERN	
WAVEFORMS	53

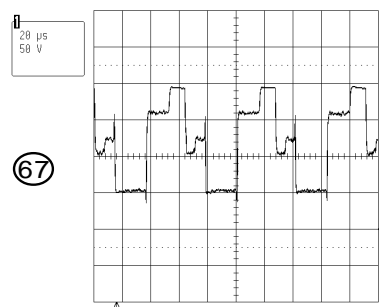
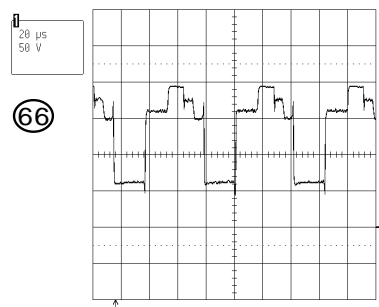
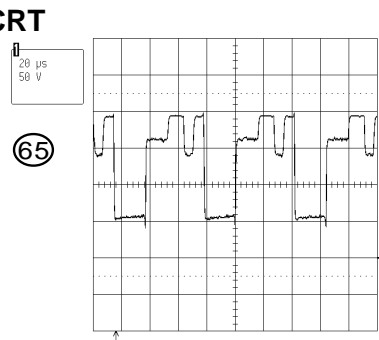
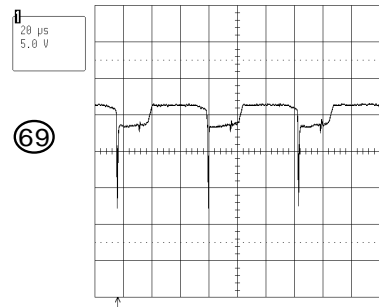

NOTE: The following waveforms were measured at the point of the corresponding balloon number in the schematic diagram.

SEMICONDUCTOR BASE CONNECTIONS

DIODE

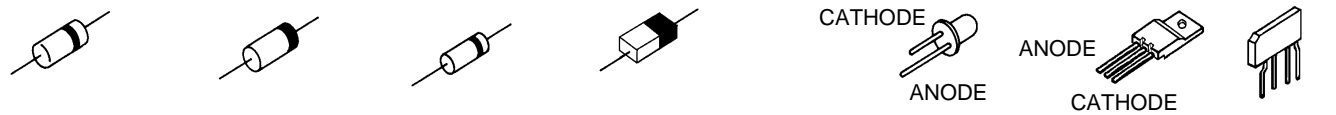

- 1SS133T-77
- 11E1N-TA1B2
- 10ELS2N-TA1B2
- 1SS355 TE-17
- AU02A-EIC
- 11ES1-EIC
- 10ELS6-TA2B5
- SLR-342VCT32
- MTZJ10B T-77
- SB040-G3
- 1N4005-EIC
- FMV-3FULF027-102
- MTZJ11B T-77
- 21DQ09N-TA2B1
- GBL06L-6177
- MTZJ27B T-77
- RMPG06J-G3
- MTZJ30B T-77
- RU2AM-EIC
- MTZJ5.1B T-77
- SB140-EIC
- MTZJ5.6B T-77
- MTZJ6.8B T-77

IC

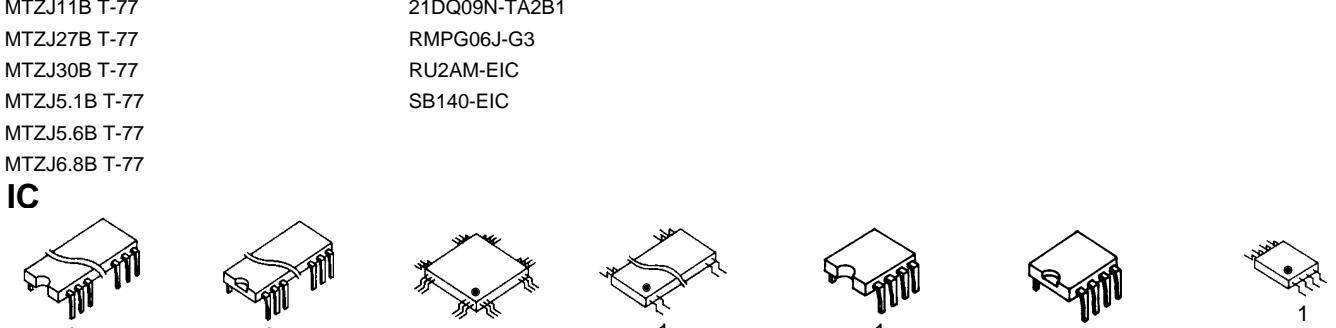

- OEC6063A
- MM1311AD
- BT865AKRF
- AN5829S
- BR24C01AF-WE2
- S-24C08ADPA-01
- NJM4580M
- TB1253N
- MD36710X
- CD4053BNSR
- HY57V161610DTC-8
- LA7151M-TP-T1
- M62420FP
- PCM1716E
- SN74LV4052APW
- ZR36703

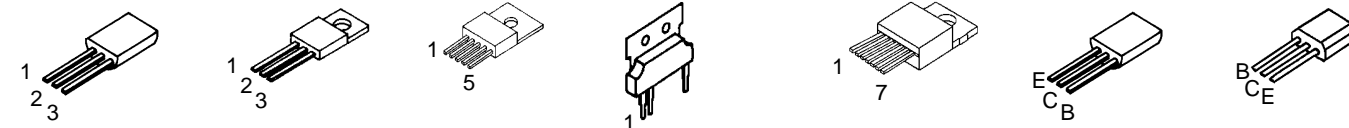

- PST600C
- KIA7805API
- STR-G6624
- AN7522
- AN5522
- 2SA1013 (TPE6)
- 2SC1740SP TP
- 2SA1624-AA
- KRC111MAT
- 2SB1131(S,T)-AE
- KRC114MAT
- 2SC2909(S,T)-AA
- KTC3198-AT(Y,GR)
- 2SD1246(S,T)-AA
- KTA1266-AT(Y,GR)
- KTA1271_Y-AT

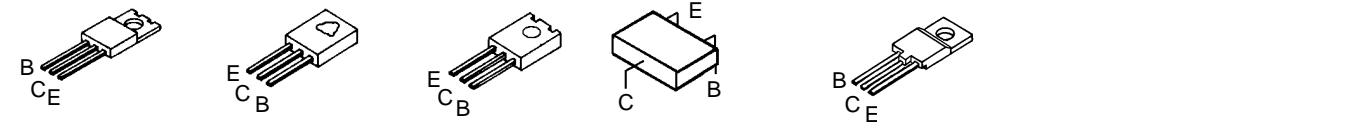

- 2SC4160-OEC-YAC1
- 2SC2621(D,E)-RAC
- 2SB1143(S,T,U)
- 2SA1037AKT146R,S
- 2SD2499(LBOEC1)
- 2SD1667(R,S)
- 2SC2412KT146 R,S
- 2SC2412KT147(R,S)
- 2SC2814(F3,F4)-T
- DTA114EKAT146
- DTA143EKAT146
- DTC144EKAT146
- KRC103RTK
- KRC111RTK

STEREO

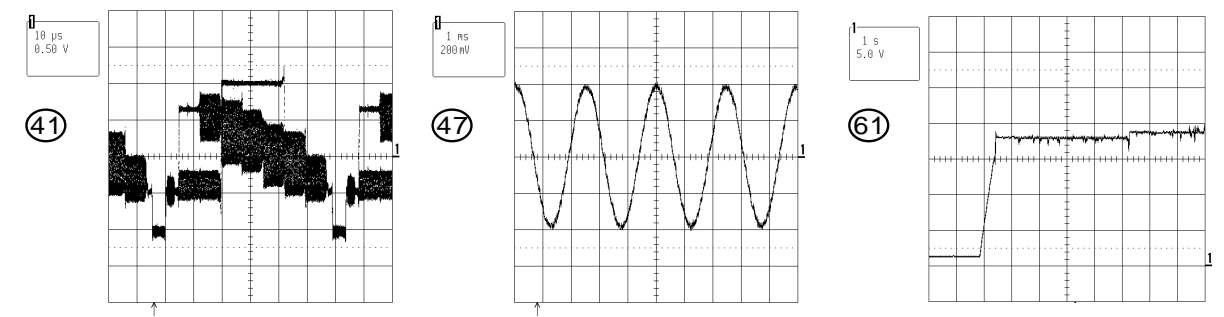
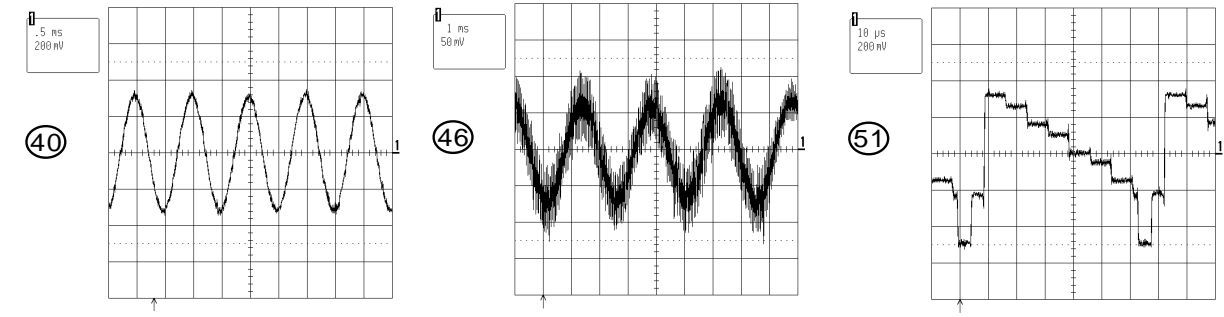

TV POWER

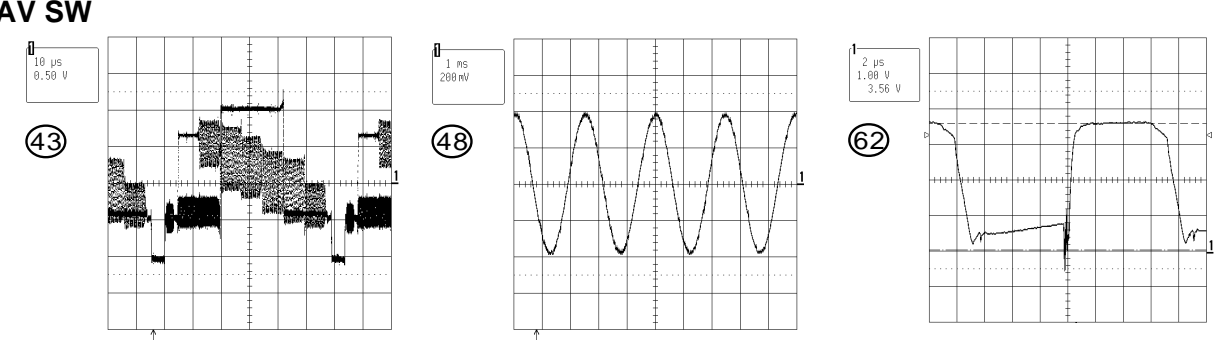

COMB FILTER

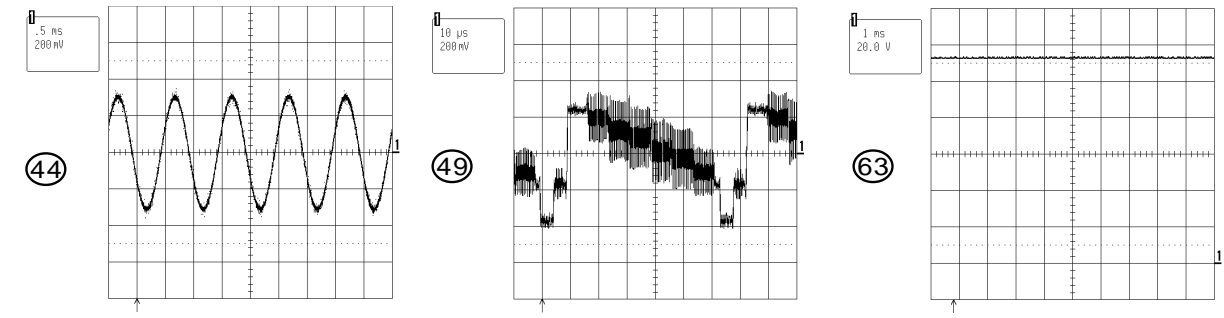

DEFLECTION

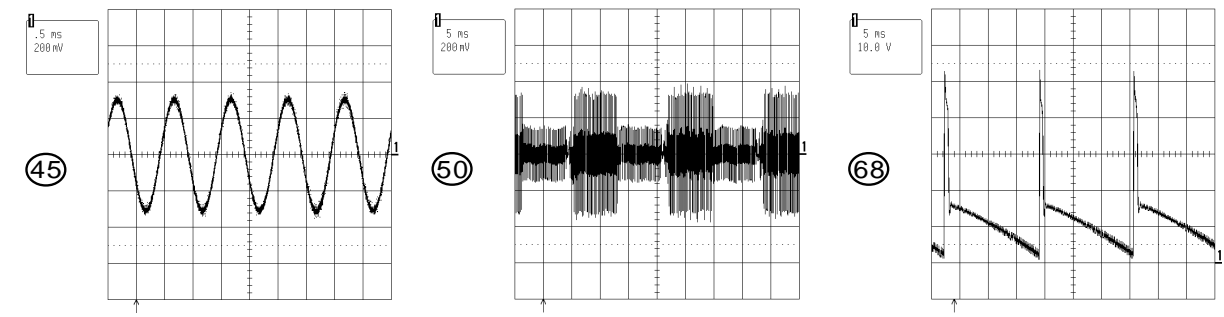

NOTE: The following waveforms were measured at the point of the corresponding balloon number in the schematic diagram.

BLOCK DIAGRAM

TV BLOCK DIAGRAM

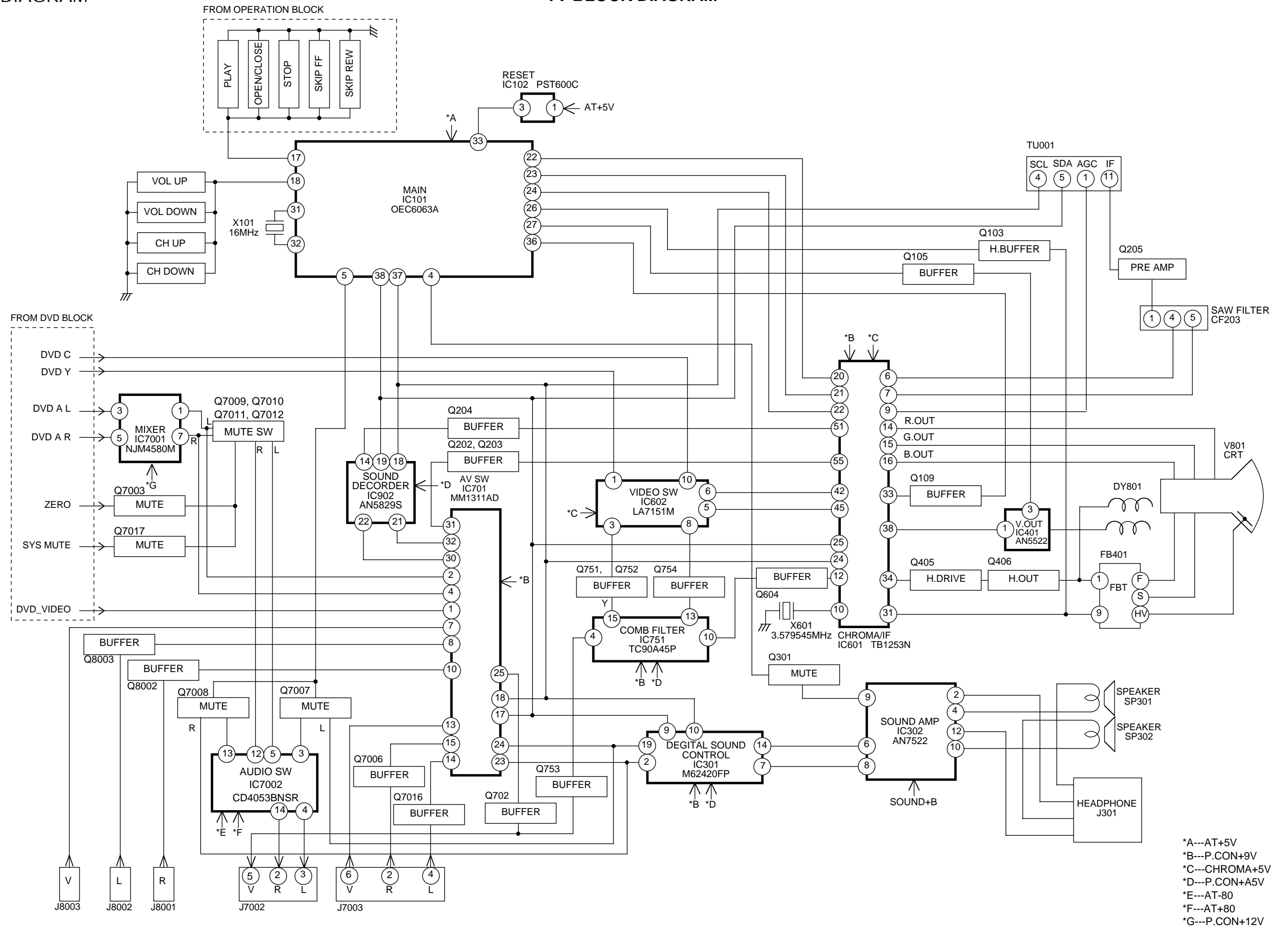

DVD BLOCK DIAGRAM

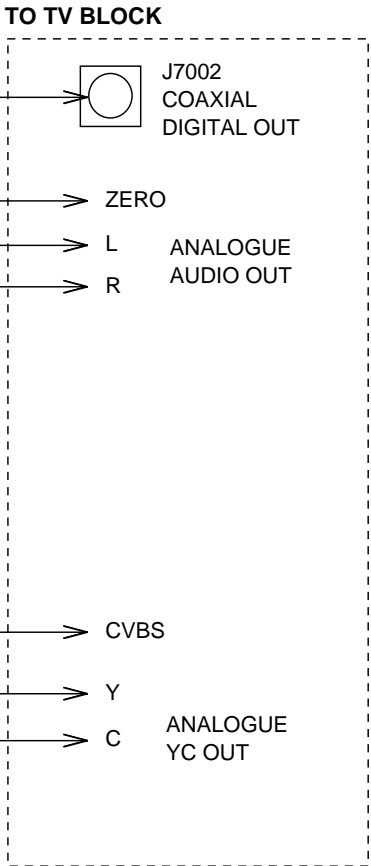
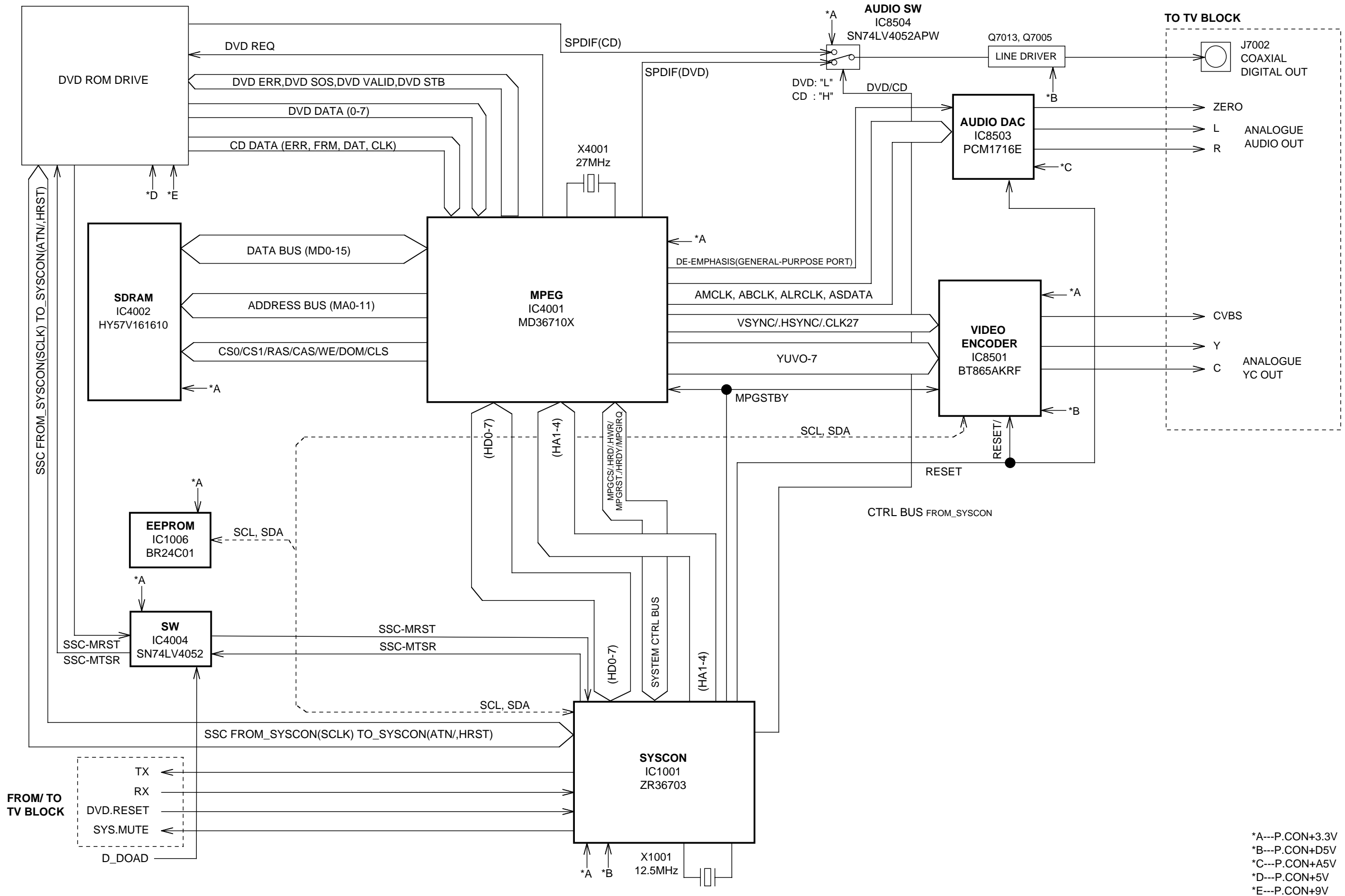

*A---P.CON+3.3V
 *B---P.CON+D5V
 *C---P.CON+A5V
 *D---P.CON+5V
 *E---P.CON+9V

POWER BLOCK DIAGRAM

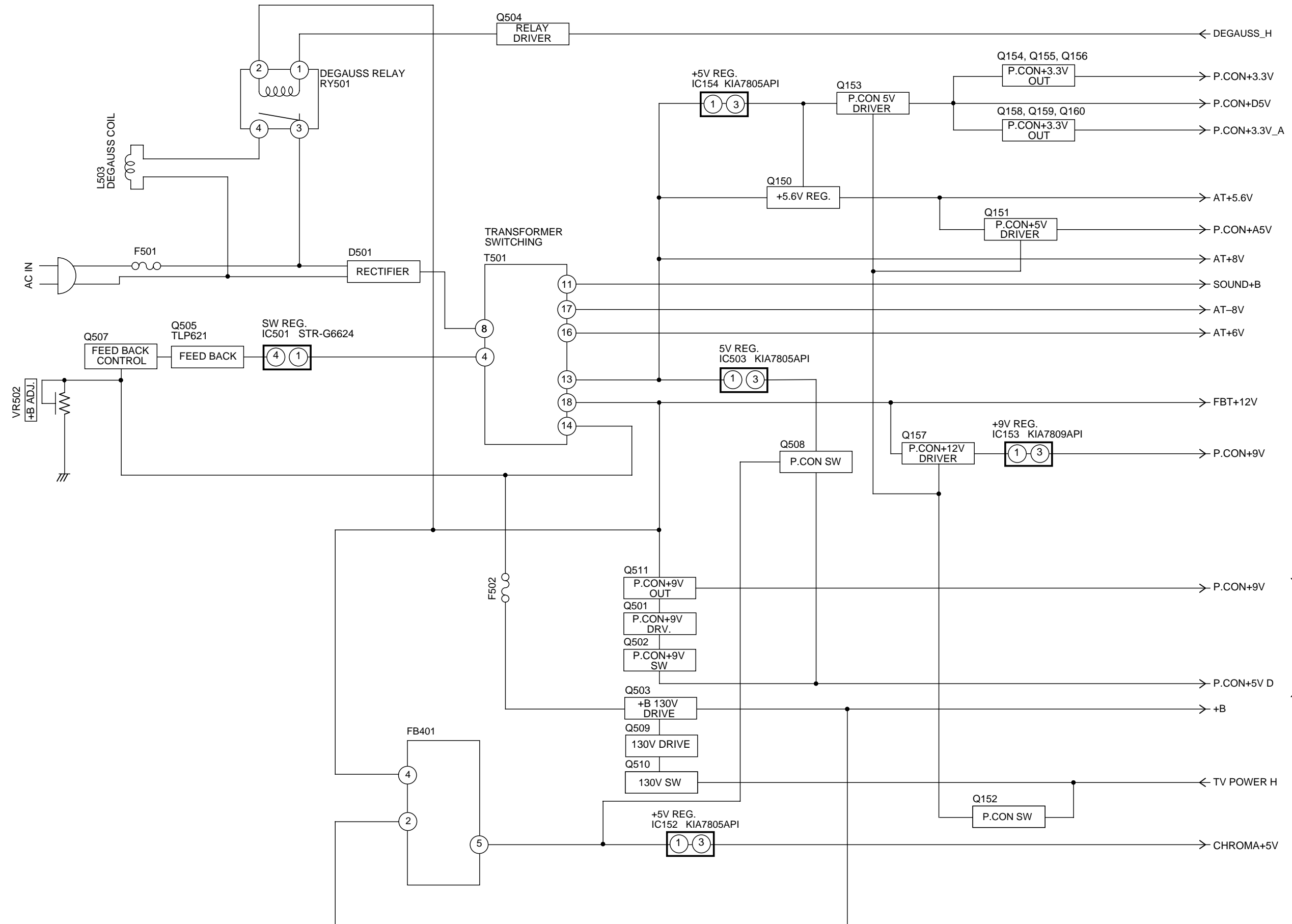

LOADER

WIRING CONNECTION DIAGRAM

INTERCONNECTION DIAGRAM

CAUTION: SINCE THESE PARTS MARKED BY ARE CRITICAL FOR SAFETY, USE ONES DESCRIBED IN PARTS LIST ONLY.

ATTENTION: LES PIÉCES REPARÉES PAR UN ÉTANT DANGEREUSES AN POINT DE VUE SECURITE N'UTILISER QUE CELLS DECRITES DANS LA NOMENCLATURE DES PIÉCES.

NOTE: THIS INTERCONNECTION DIAGRAM IS THE LATEST AT THE TIME OF PRINTING AND SUBJECT TO CHANGE WITHOUT NOTICE.

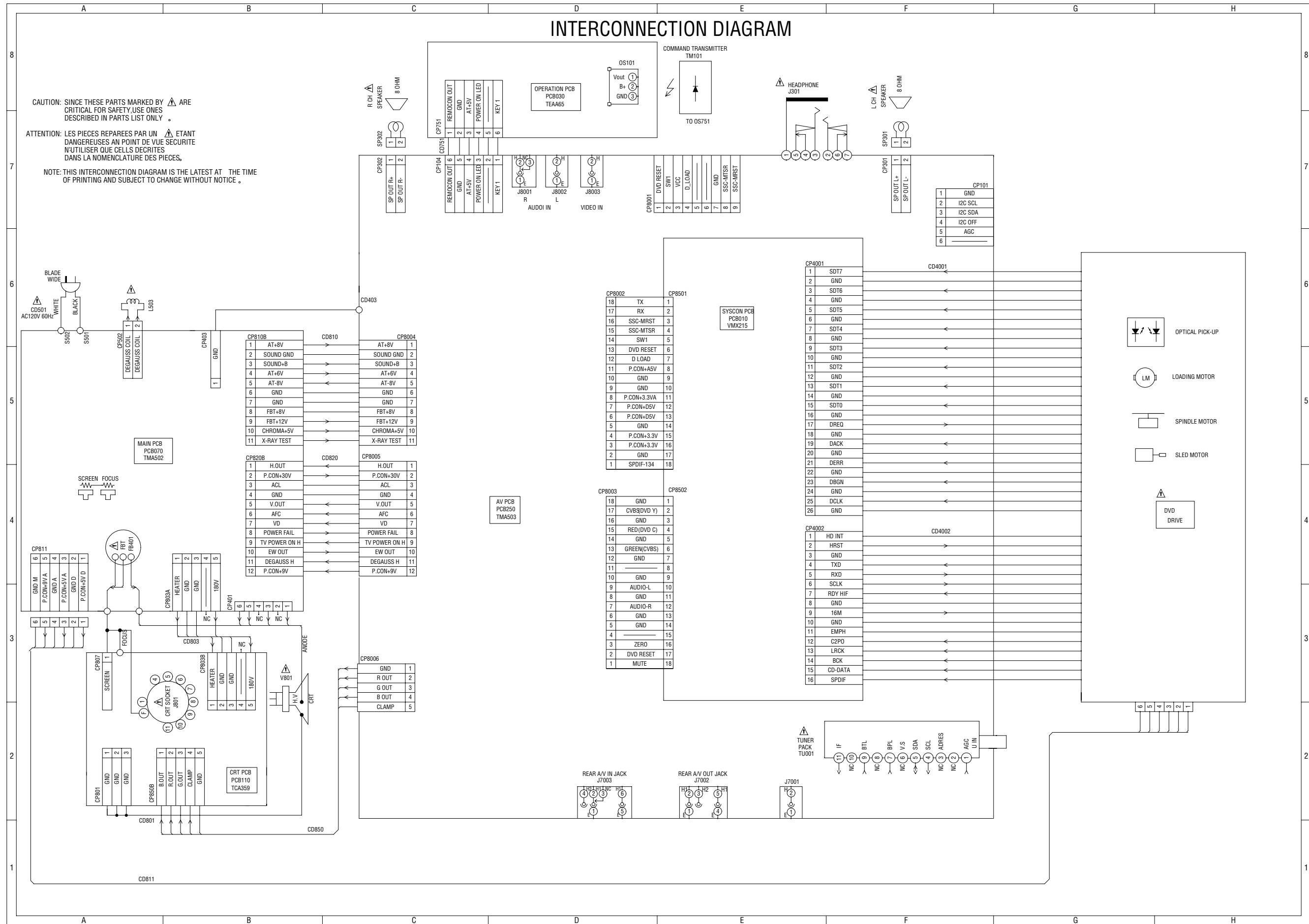

Circuit Diagram

[SYSCON PWB(MPEG) CIRCUIT DIAGRAM]

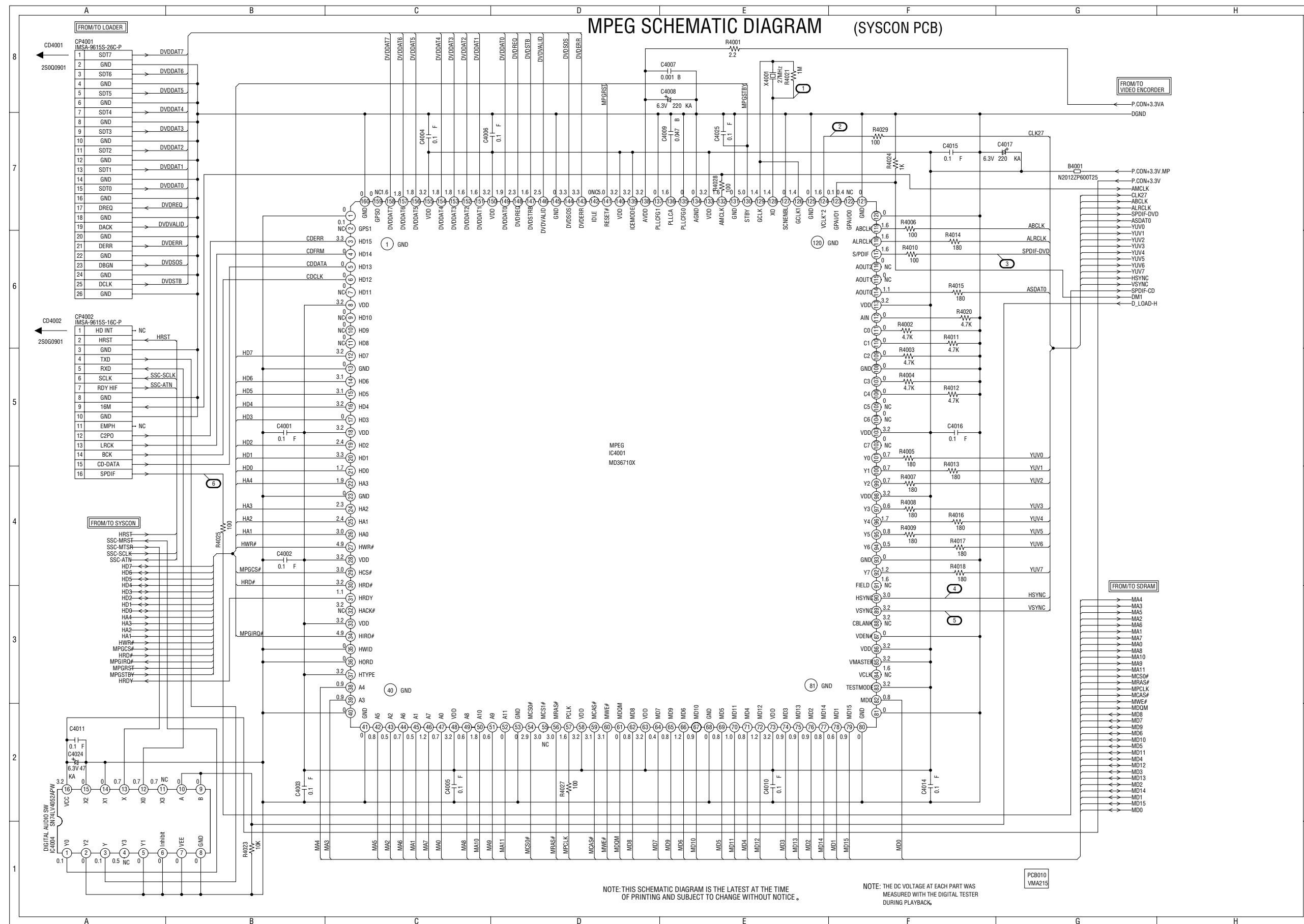

NOTE: THIS SCHEMATIC DIAGRAM IS THE LATEST AT THE TIME OF PRINTING AND SUBJECT TO CHANGE WITHOUT NOTICE.

NOTE: THE DC VOLTAGE AT EACH PART WAS MEASURED WITH THE DIGITAL TESTER DURING PLAYBACK.

PCB010 VMA215

[SYSCON PWB(SDRAM) CIRCUIT DIAGRAM]

SDRAM SCHEMATIC DIAGRAM (SYSCON PCB)

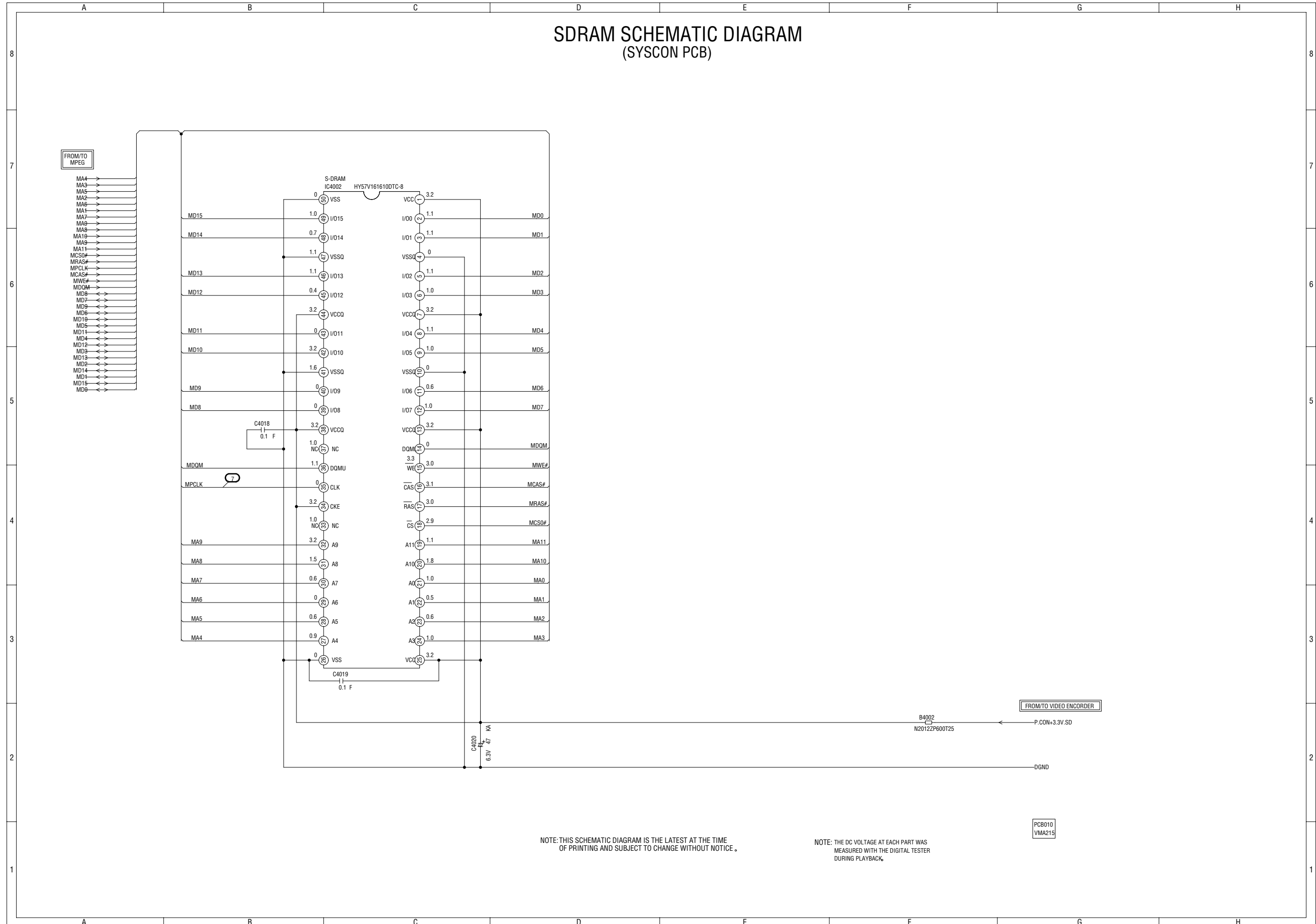

NOTE: THIS SCHEMATIC DIAGRAM IS THE LATEST AT THE TIME OF PRINTING AND SUBJECT TO CHANGE WITHOUT NOTICE.

NOTE: THE DC VOLTAGE AT EACH PART WAS MEASURED WITH THE DIGITAL TESTER DURING PLAYBACK.

[SYSCON PWB(SYSCON) CIRCUIT DIAGRAM]

SYSCON SCHEMATIC DIAGRAM (SYSCON PCB)

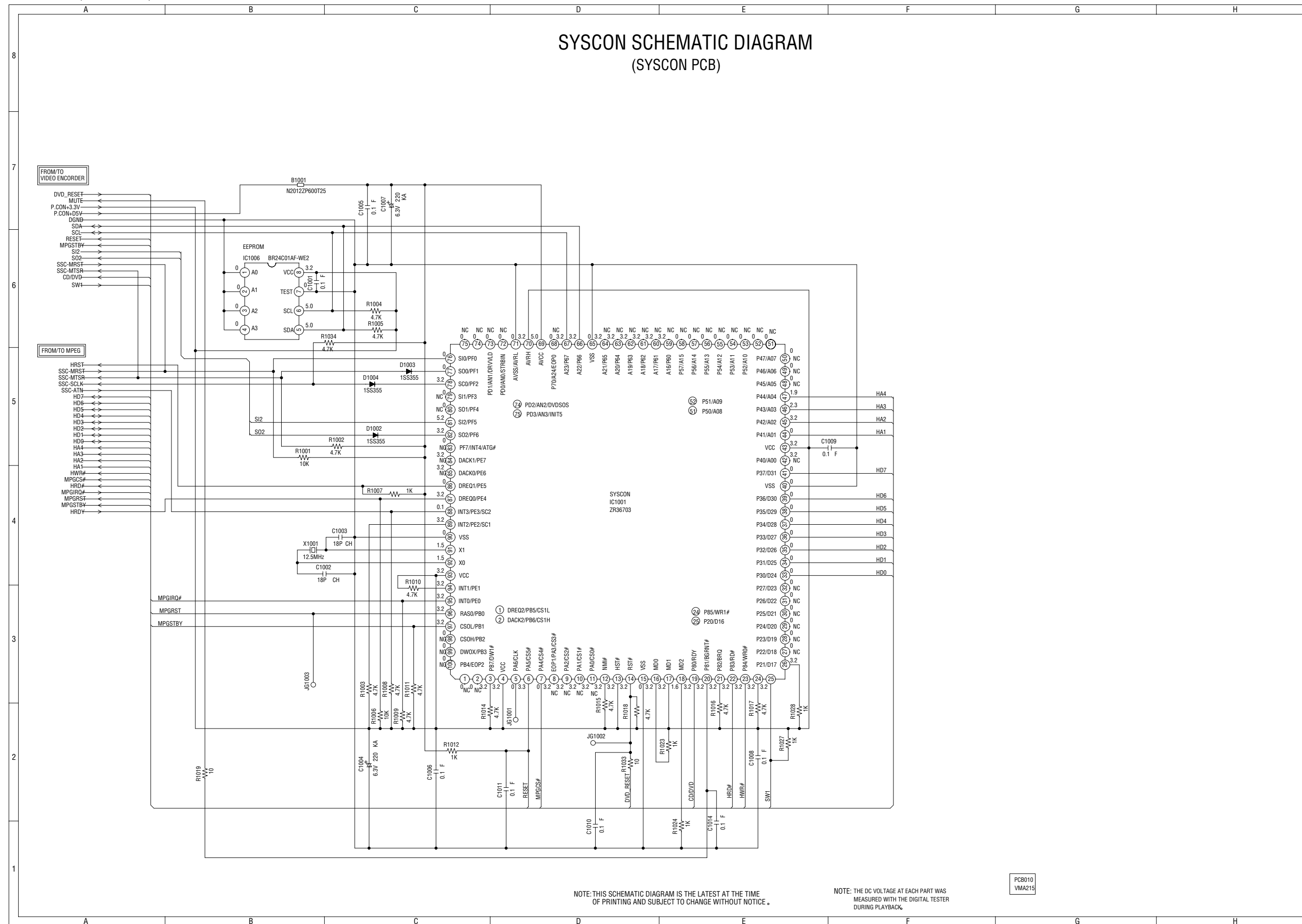

NOTE: THIS SCHEMATIC DIAGRAM IS THE LATEST AT THE TIME OF PRINTING AND SUBJECT TO CHANGE WITHOUT NOTICE.

NOTE: THE DC VOLTAGE AT EACH PART WAS MEASURED WITH THE DIGITAL TESTER DURING PLAYBACK.

PCB010
VMA215

[SYSCON PWB(VIDEO ENCODER) CIRCUIT DIAGRAM]

VIDEO ENCODER SCHEMATIC DIAGRAM (SYSCON PCB)

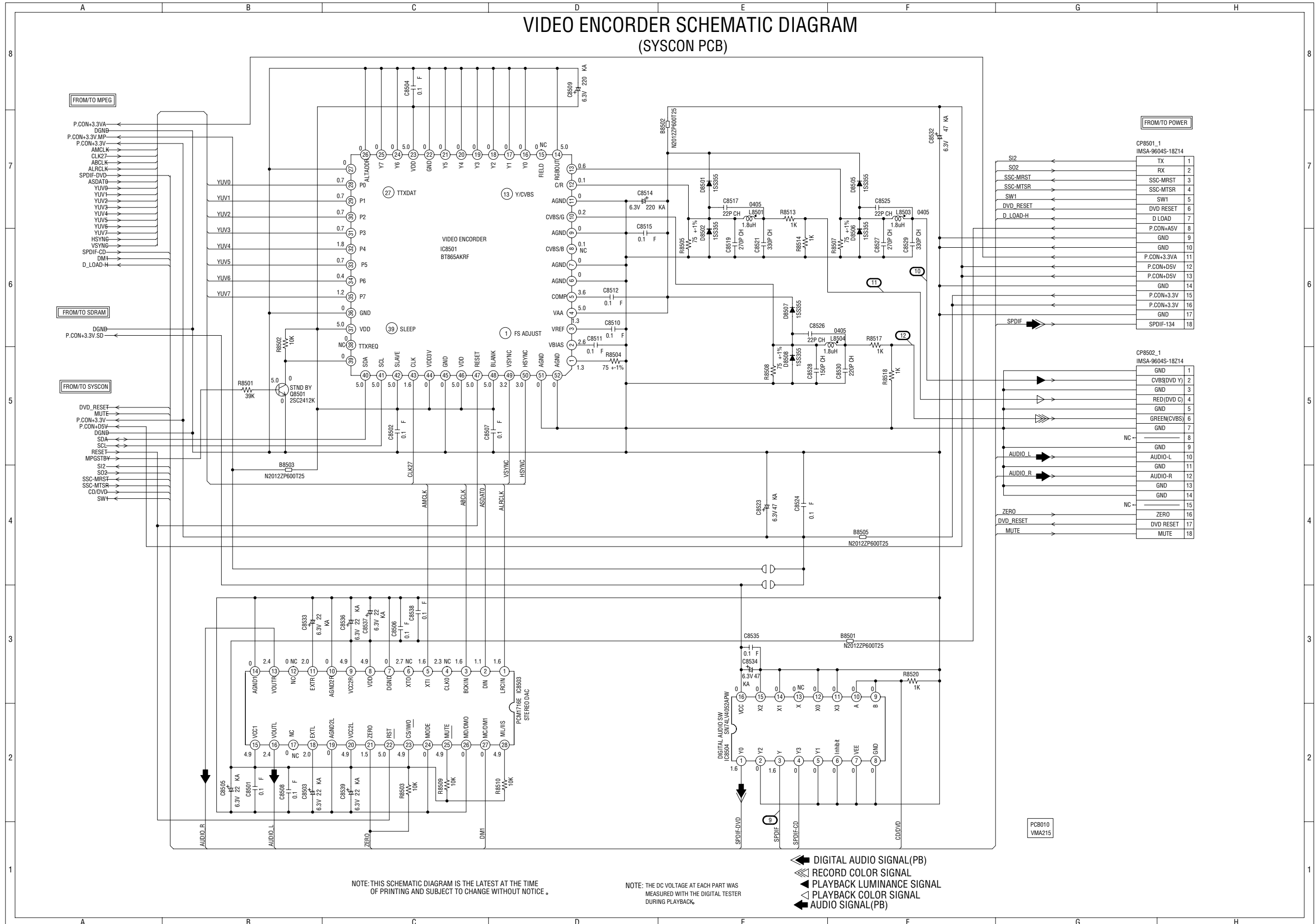

FROM/TO MPEG

P.CON+3.3V
 DGND
 P.CON+3.3V MP
 P.CON+3.3V
 AMCLK
 CLK27
 ARCLK
 ALRCLK
 SPDIF-DVD
 ASDAT9
 YUV0
 YUV1
 YUV2
 YUV3
 YUV4
 YUV5
 YUV6
 YUV7
 HSYNC
 VSYNC
 SPDIF-CD
 DM1
 D_LOAD-H

FROM/TO SDRAM

DGND
 P.CON+3.3V SD

FROM/TO SYSCON

DVD_RESET
 MUTE
 P.CON+3.3V
 P.CON+3.3V
 DGND
 SDA
 SCL
 RESET
 MPGSTBY
 SI2
 SO2
 SSC-MRST
 SSC-MTSR
 CD/DVD
 SW1

FROM/TO POWER

CP8501_1	IMSA-9604S-18214
TX	1
RX	2
SSC-MRST	3
SSC-MTSR	4
SW1	5
DVD_RESET	6
D_LOAD	7
P.CON+3.3V	8
GND	9
GND	10
P.CON+3.3V	11
P.CON+3.3V	12
P.CON+3.3V	13
GND	14
P.CON+3.3V	15
P.CON+3.3V	16
GND	17
SPDIF-134	18

CP8502_1	IMSA-9604S-18214
GND	1
CVBS(DVD Y)	2
GND	3
RED(DVD C)	4
GND	5
GREEN(CVBS)	6
GND	7
NC	8
GND	9
AUDIO-L	10
GND	11
AUDIO-R	12
GND	13
GND	14
NC	15
ZERO	16
DVD_RESET	17
MUTE	18

NOTE: THIS SCHEMATIC DIAGRAM IS THE LATEST AT THE TIME OF PRINTING AND SUBJECT TO CHANGE WITHOUT NOTICE.

NOTE: THE DC VOLTAGE AT EACH PART WAS MEASURED WITH THE DIGITAL TESTER DURING PLAYBACK.

- ▶ DIGITAL AUDIO SIGNAL (PB)
- ▶ RECORD COLOR SIGNAL
- ▶ PLAYBACK LUMINANCE SIGNAL
- ▶ PLAYBACK COLOR SIGNAL
- ▶ AUDIO SIGNAL (PB)

[AV PWB(POWER) CIRCUIT DIAGRAM]

POWER SCHEMATIC DIAGRAM (AV PCB)

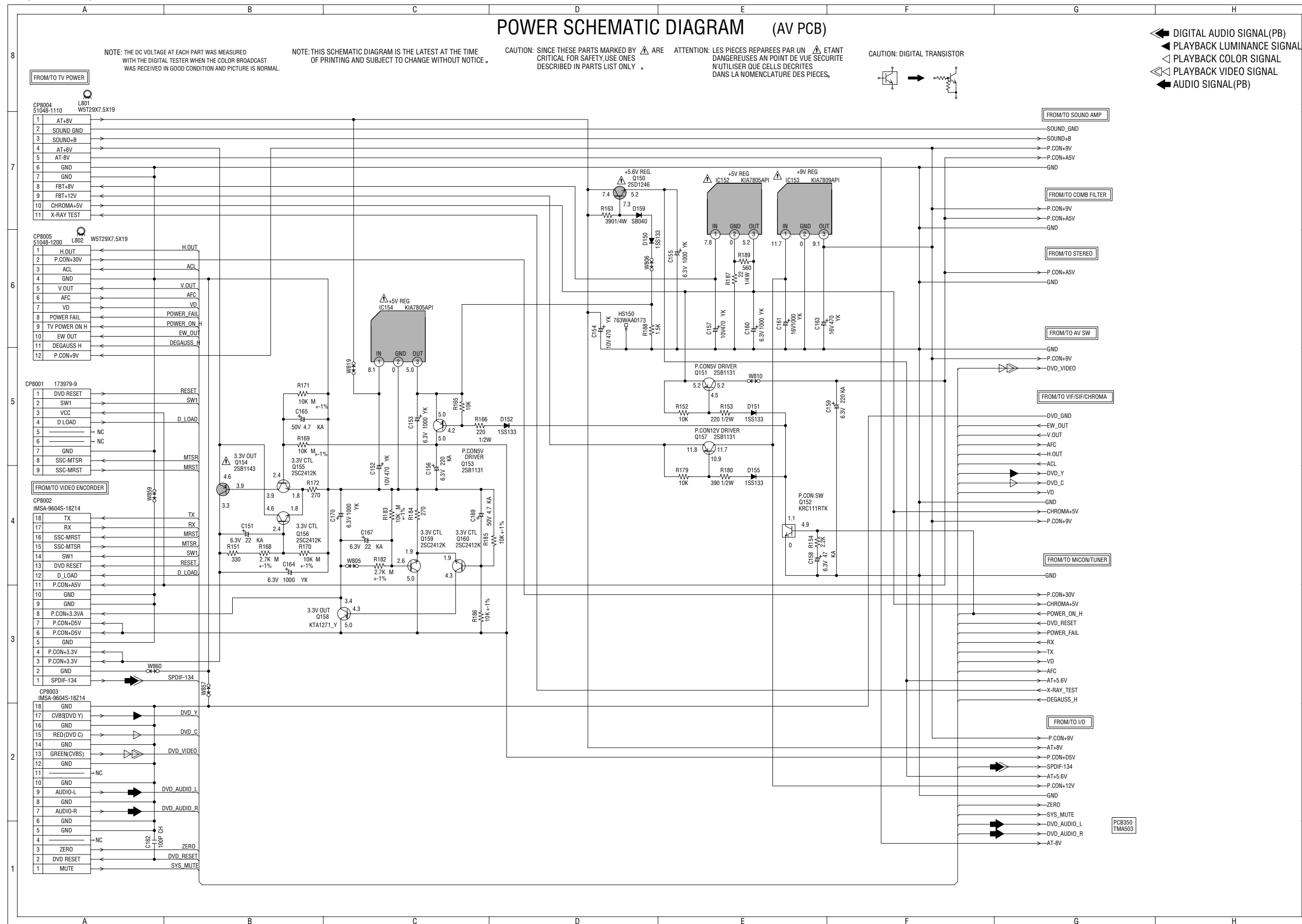

[AV PWB(MICON/TUNER) CIRCUIT DIAGRAM]

MICON /TUNER SCHEMATIC DIAGRAM (AV PCB)

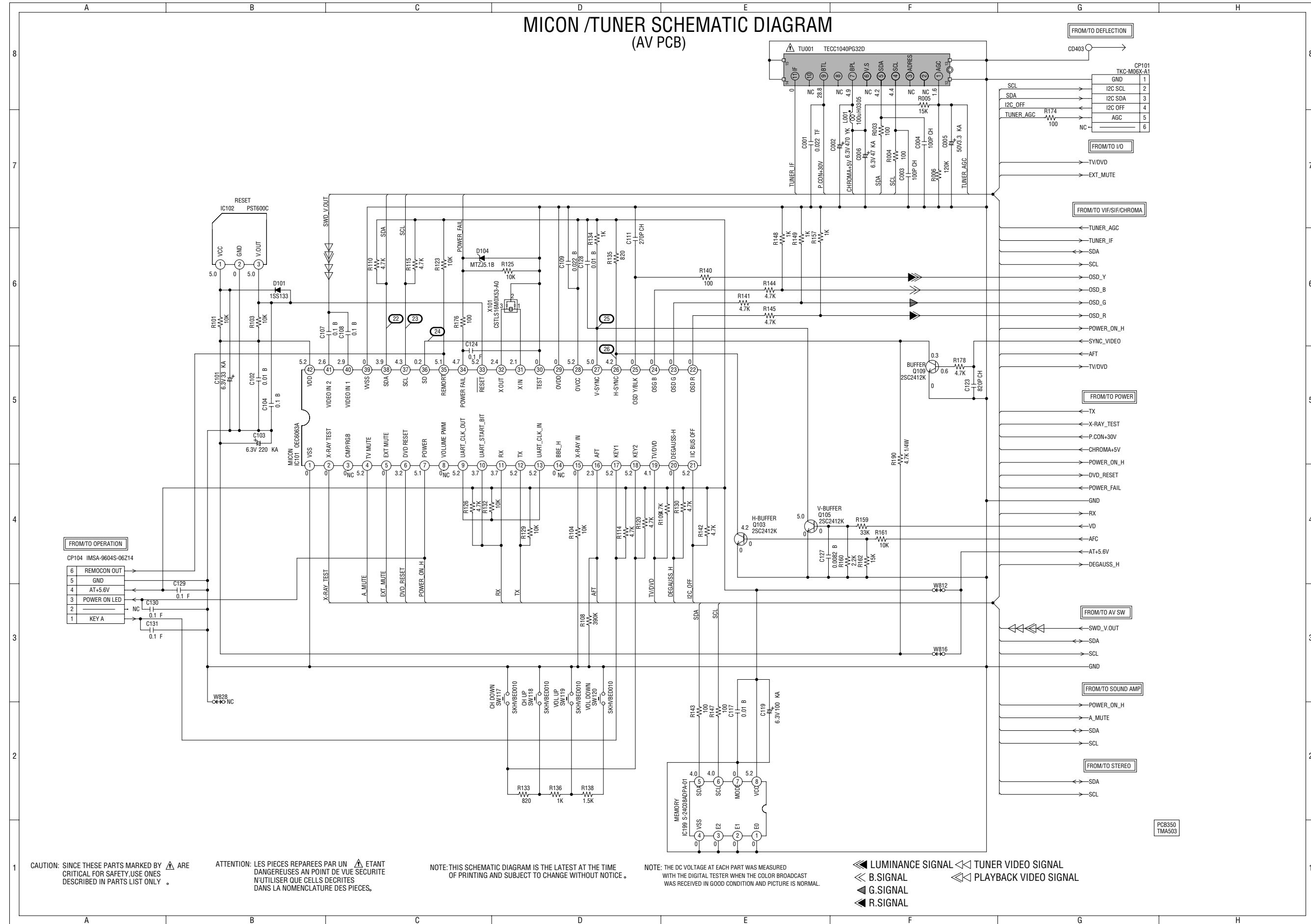

CAUTION: SINCE THESE PARTS MARKED BY ARE CRITICAL FOR SAFETY, USE ONES DESCRIBED IN PARTS LIST ONLY.

ATTENTION: LES PIECES REPARÉES PAR UN ÉTANT DANGEREUSES AU POINT DE VUE SÉCURITÉ N'UTILISER QUE CELLES DÉCRITES DANS LA NOMENCLATURE DES PIÈCES.

NOTE: THIS SCHEMATIC DIAGRAM IS THE LATEST AT THE TIME OF PRINTING AND SUBJECT TO CHANGE WITHOUT NOTICE.

NOTE: THE DC VOLTAGE AT EACH PART WAS MEASURED WITH THE DIGITAL TESTER WHEN THE COLOR BROADCAST WAS RECEIVED IN GOOD CONDITION AND PICTURE IS NORMAL.

- LUMINANCE SIGNAL
- B.SIGNAL
- G.SIGNAL
- R.SIGNAL
- TUNER VIDEO SIGNAL
- PLAYBACK VIDEO SIGNAL

[AV PWB(VIF/SIF/CHROMA) CIRCUIT DIAGRAM]

VIF/SIF/CHROMA SCHEMATIC DIAGRAM (AV PCB)

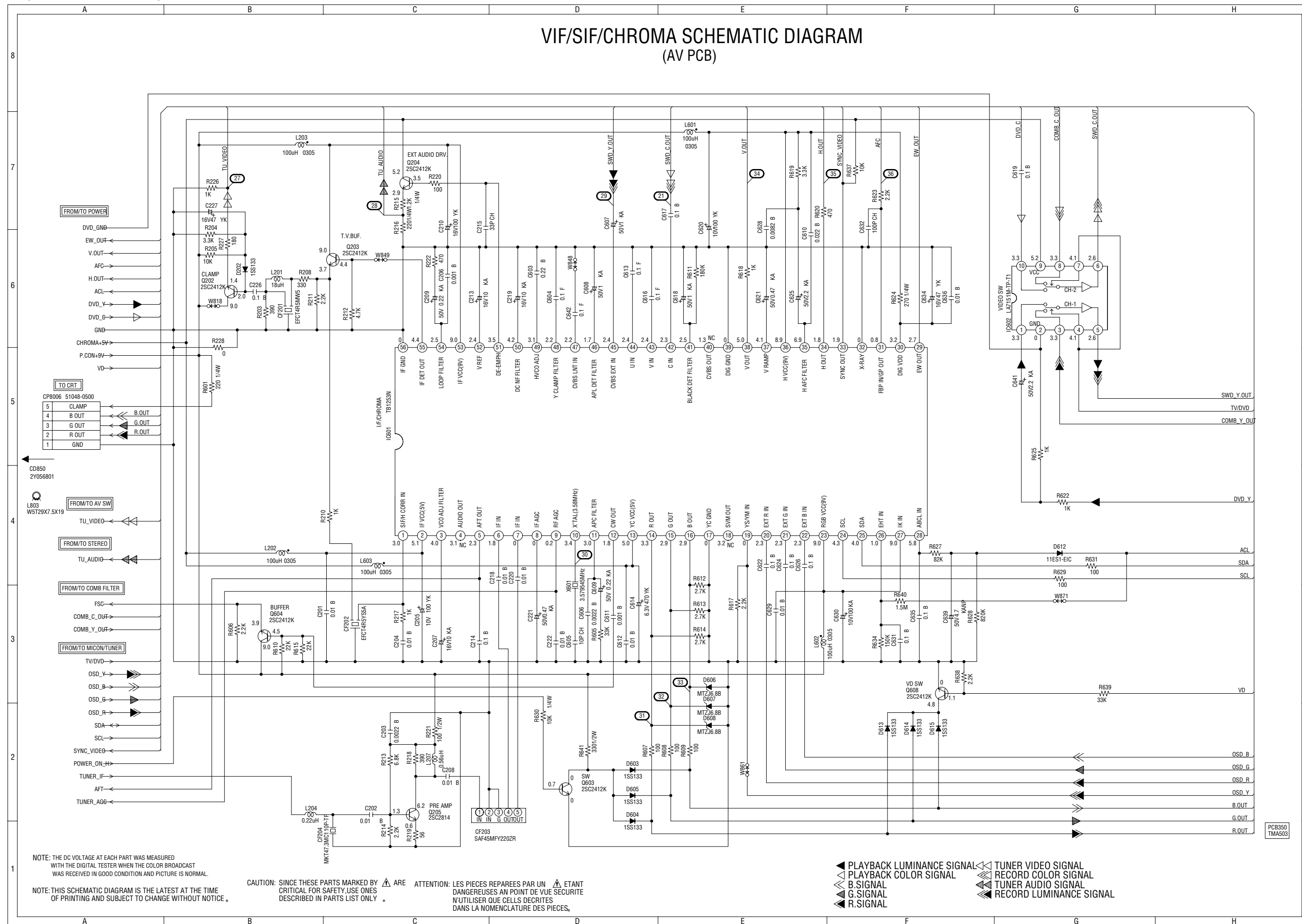

NOTE: THE DC VOLTAGE AT EACH PART WAS MEASURED WITH THE DIGITAL TESTER WHEN THE COLOR BROADCAST WAS RECEIVED IN GOOD CONDITION AND PICTURE IS NORMAL.

NOTE: THIS SCHEMATIC DIAGRAM IS THE LATEST AT THE TIME OF PRINTING AND SUBJECT TO CHANGE WITHOUT NOTICE.

CAUTION: SINCE THESE PARTS MARKED BY Δ ARE CRITICAL FOR SAFETY, USE ONES DESCRIBED IN PARTS LIST ONLY.

ATTENTION: LES PIÈCES RÉPARÉES PAR UN Δ ÉTANT DANGEREUSES AN POINT DE VUE SÉCURITÉ N'UTILISER QUE CELLES DÉCRITES DANS LA NOMENCLATURE DES PIÈCES.

- ▶ PLAYBACK LUMINANCE SIGNAL
- ▶▶ PLAYBACK COLOR SIGNAL
- ▶▶▶ B SIGNAL
- ▶▶▶ G SIGNAL
- ▶▶▶ R SIGNAL
- ▶▶▶ TUNER VIDEO SIGNAL
- ▶▶▶ RECORD COLOR SIGNAL
- ▶▶▶ TUNER AUDIO SIGNAL
- ▶▶▶ RECORD LUMINANCE SIGNAL

[AV PWB(SOUND AMP) CIRCUIT DIAGRAM]

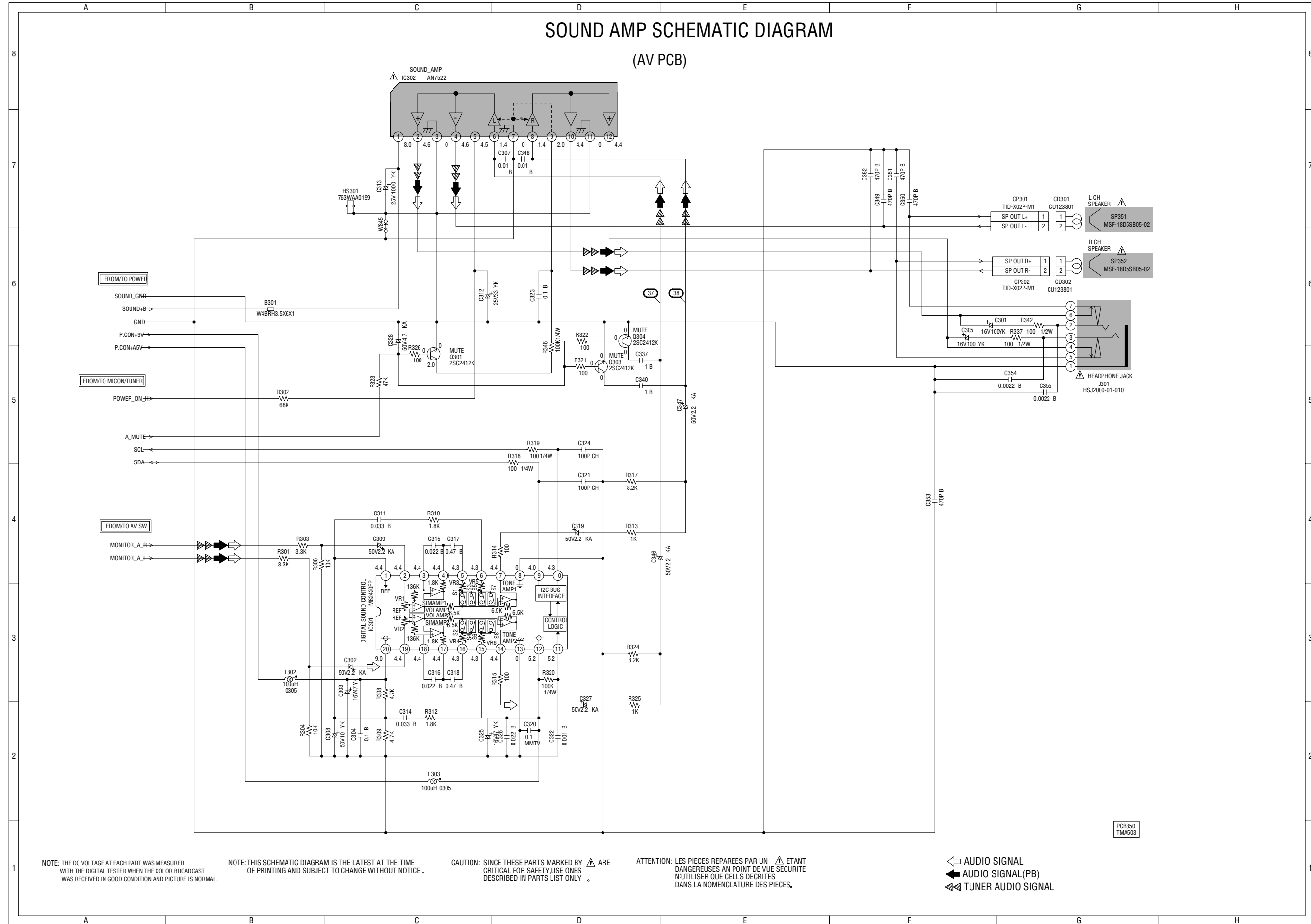

NOTE: THE DC VOLTAGE AT EACH PART WAS MEASURED WITH THE DIGITAL TESTER WHEN THE COLOR BROADCAST WAS RECEIVED IN GOOD CONDITION AND PICTURE IS NORMAL.

NOTE: THIS SCHEMATIC DIAGRAM IS THE LATEST AT THE TIME OF PRINTING AND SUBJECT TO CHANGE WITHOUT NOTICE.

CAUTION: SINCE THESE PARTS MARKED BY Δ ARE CRITICAL FOR SAFETY, USE ONES DESCRIBED IN PARTS LIST ONLY.

ATTENTION: LES PIÈCES RÉPARÉES PAR UN Δ ÉTANT DANGEREUSES AN POINT DE VUE SECURITE N'UTILISER QUE CELLS DÉCRITES DANS LA NOMENCLATURE DES PIÈCES.

◁ AUDIO SIGNAL
▶ AUDIO SIGNAL (PB)
◀▶ TUNER AUDIO SIGNAL

PCB350
TMA503

[AV PWB(AV SW) CIRCUIT DIAGRAM]

AV SW SCHEMATIC DIAGRAM (AV PCB)

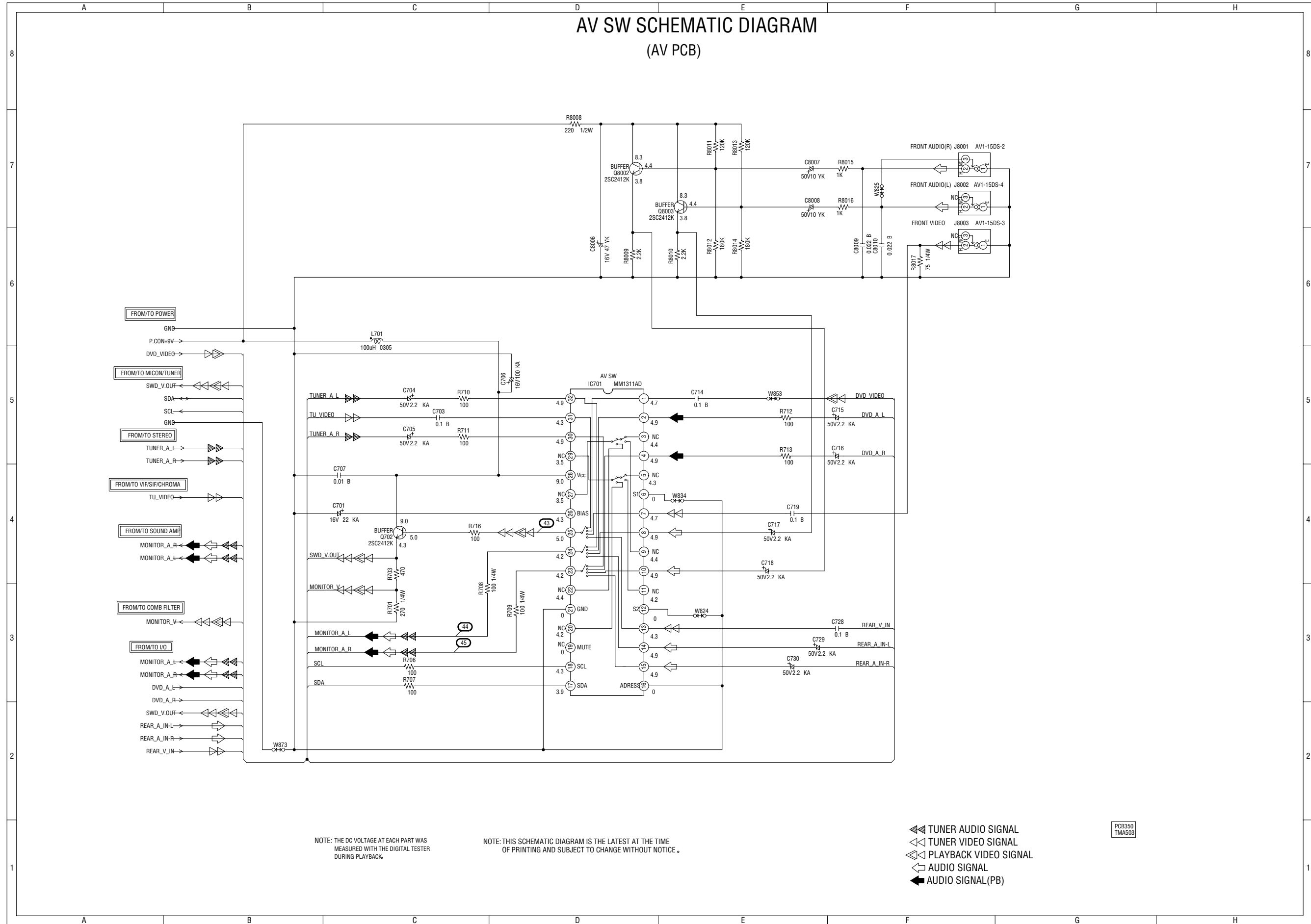

NOTE: THE DC VOLTAGE AT EACH PART WAS MEASURED WITH THE DIGITAL TESTER DURING PLAYBACK.

NOTE: THIS SCHEMATIC DIAGRAM IS THE LATEST AT THE TIME OF PRINTING AND SUBJECT TO CHANGE WITHOUT NOTICE.

- ▶ TUNER AUDIO SIGNAL
- ◀ TUNER VIDEO SIGNAL
- ▶▶ PLAYBACK VIDEO SIGNAL
- ◀▶ AUDIO SIGNAL
- ▶▶▶ AUDIO SIGNAL (PB)

PCB350
TMA503

[AV PWB(COMB FILTER) CIRCUIT DIAGRAM]

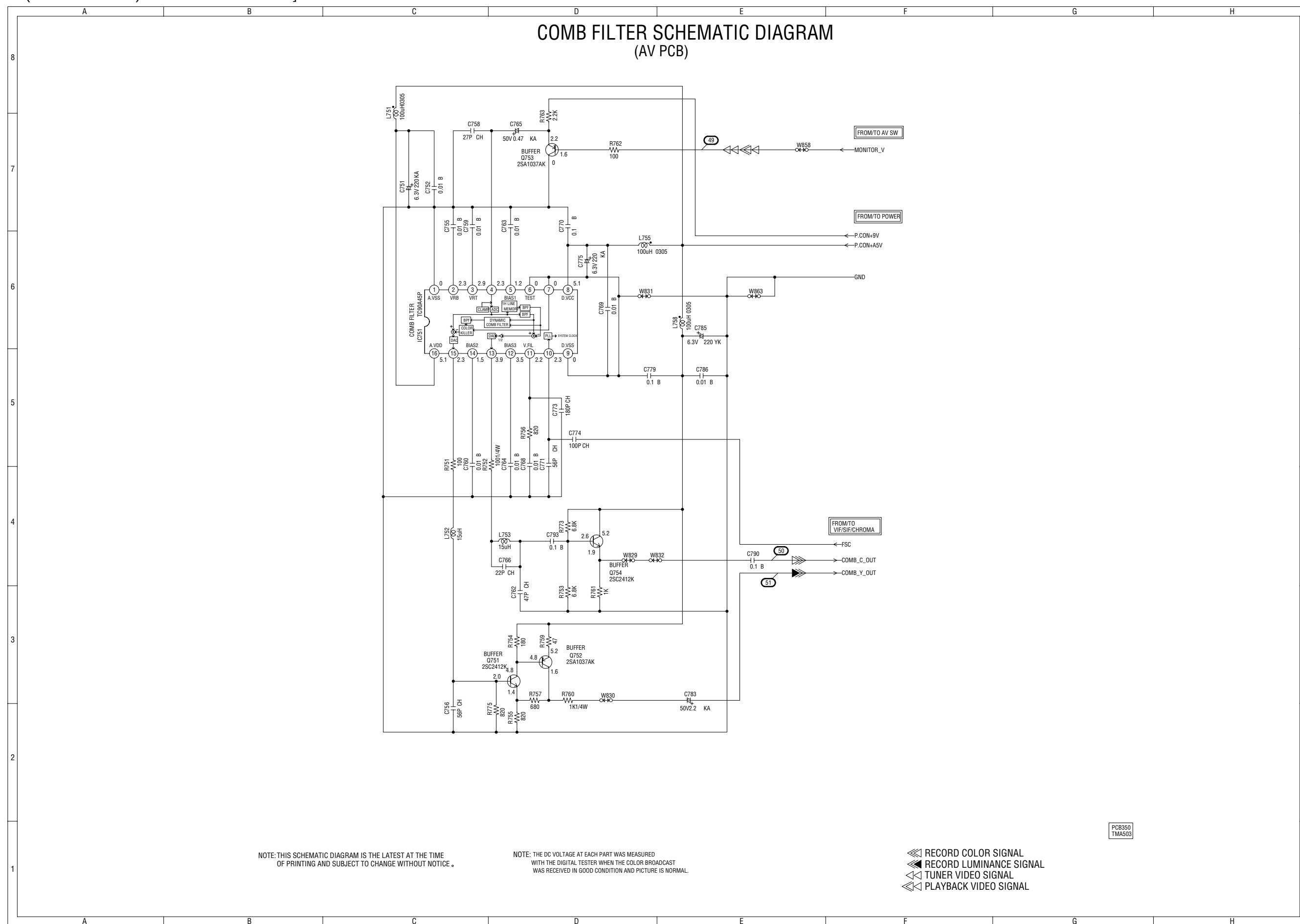

[AV PWB(STEREO) CIRCUIT DIAGRAM]

STEREO SCHEMATIC DIAGRAM
(AV PCB)

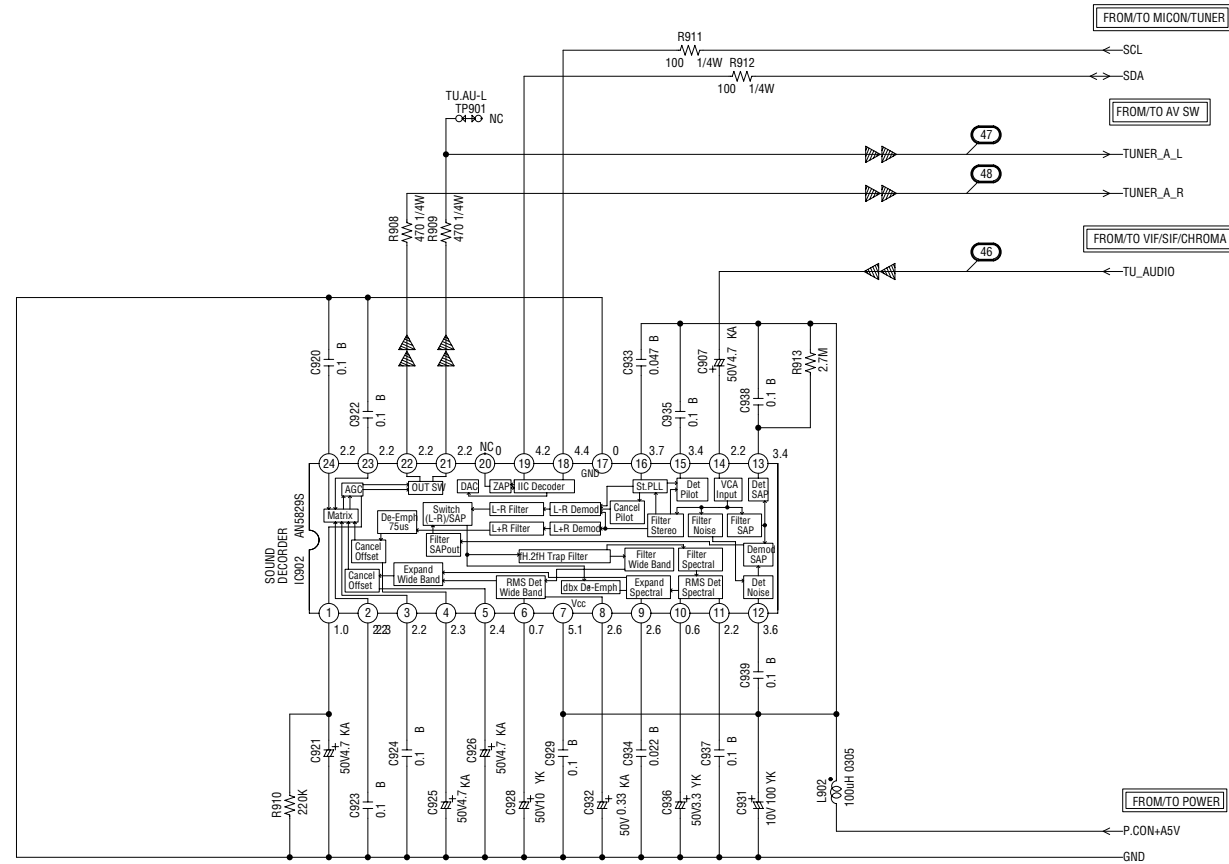

NOTE: THE DC VOLTAGE AT EACH PART WAS MEASURED WITH THE DIGITAL TESTER WHEN THE COLOR BROADCAST WAS RECEIVED IN GOOD CONDITION AND PICTURE IS NORMAL.

NOTE: THIS SCHEMATIC DIAGRAM IS THE LATEST AT THE TIME OF PRINTING AND SUBJECT TO CHANGE WITHOUT NOTICE.

▶ TUNER AUDIO SIGNAL

PCB350
TMA503

[OPERATON PWB CIRCUIT DIAGRAM]

OPERATION SCHEMATIC DIAGRAM
(OPERATION PCB)

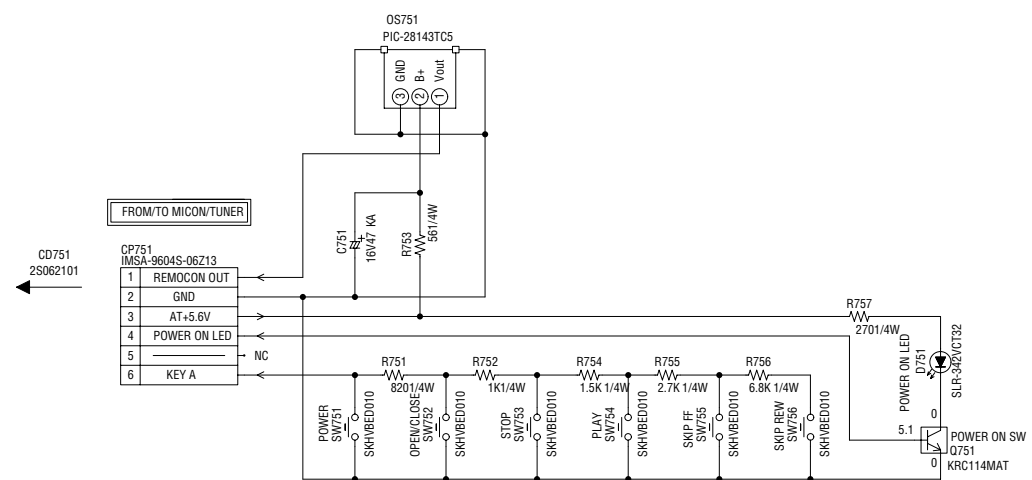

CAUTION: DIGITAL TRANSISTOR



NOTE: THIS SCHEMATIC DIAGRAM IS THE LATEST AT THE TIME OF PRINTING AND SUBJECT TO CHANGE WITHOUT NOTICE .

NOTE: THE DC VOLTAGE AT EACH PART WAS MEASURED WITH THE DIGITAL TESTER WHEN THE COLOR BROADCAST WAS RECEIVED IN GOOD CONDITION AND PICTURE IS NORMAL.

PCB030
TEAA65

[MAIN PWB(TV POWER) CIRCUIT DIAGRAM]

TV POWER SCHEMATIC DIAGRAM (MAIN PCB)

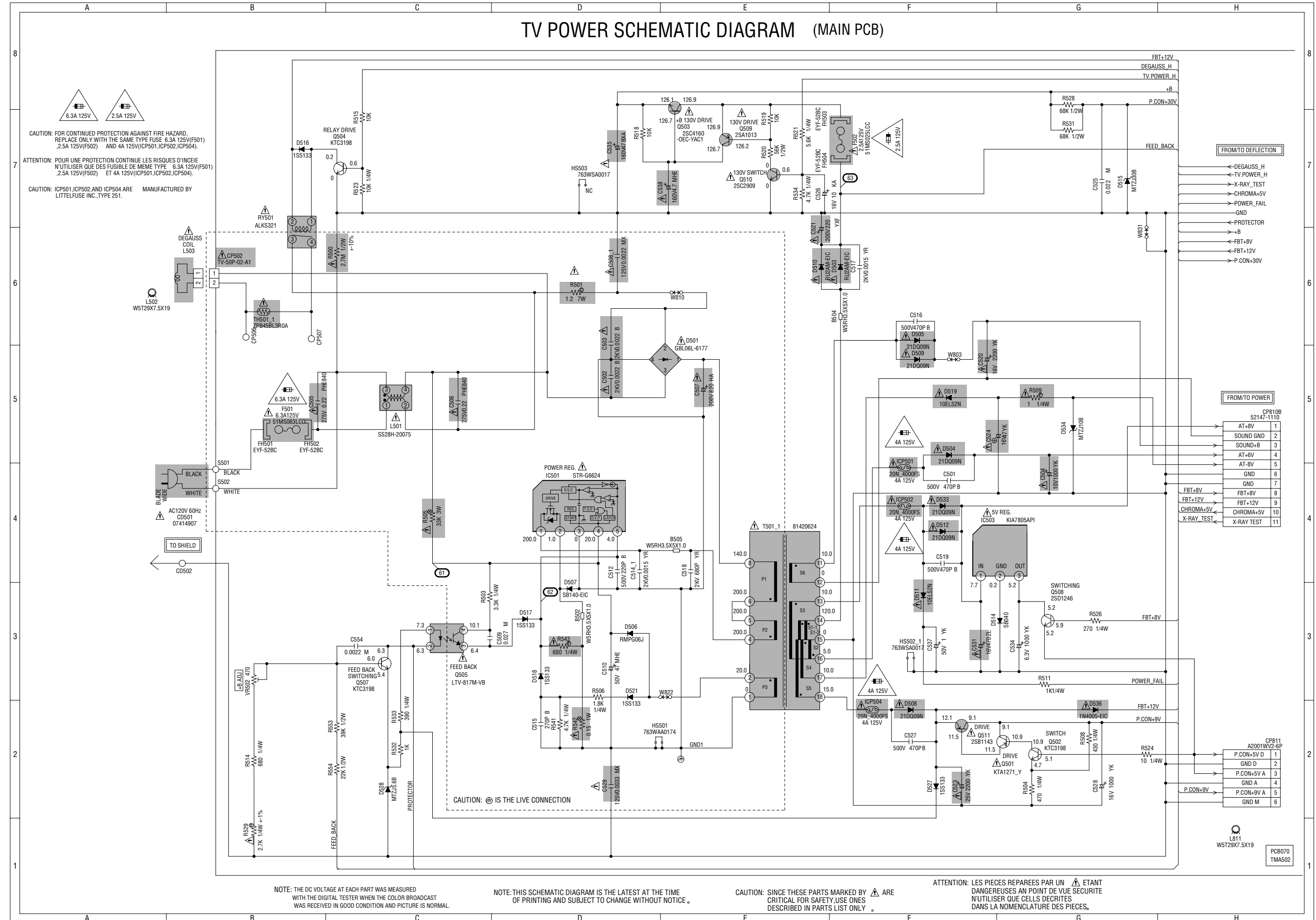

CAUTION: FOR CONTINUED PROTECTION AGAINST FIRE HAZARD, REPLACE ONLY WITH THE SAME TYPE FUSE 6.3A 125V(F501) 2.5A 125V(F502) AND 4A 125V(ICP501,ICP502,ICP504).

ATTENTION: POUR UNE PROTECTION CONTINUE LES RISQUES D'INCENDIE N'UTILISER QUE DES FUSIBLES DE MEME TYPE 6.3A 125V(F501) 2.5A 125V(F502) ET 4A 125V(ICP501,ICP502,ICP504).

CAUTION: ICP501,ICP502 AND ICP504 ARE MANUFACTURED BY LITTELFUSE INC.,TYPE 251.

NOTE: THE DC VOLTAGE AT EACH PART WAS MEASURED WITH THE DIGITAL TESTER WHEN THE COLOR BROADCAST WAS RECEIVED IN GOOD CONDITION AND PICTURE IS NORMAL.

NOTE: THIS SCHEMATIC DIAGRAM IS THE LATEST AT THE TIME OF PRINTING AND SUBJECT TO CHANGE WITHOUT NOTICE.

CAUTION: SINCE THESE PARTS MARKED WITH Δ ARE CRITICAL FOR SAFETY USE ONLY DESCRIBED IN PARTS LIST ONLY.

ATTENTION: LES PIÉCES REPARÉES PAR UN Δ ÉTANT DANGEREUSES AN POINT DE VUE SECURITE N'UTILISER QUE CELLS DECRITES DANS LA NOMENCLATURE DES PIÉCES.

[MAIN PWB(DEFLECTION) CIRCUIT DIAGRAM]

DEFLECTION SCHEMATIC DIAGRAM (MAIN PCB)

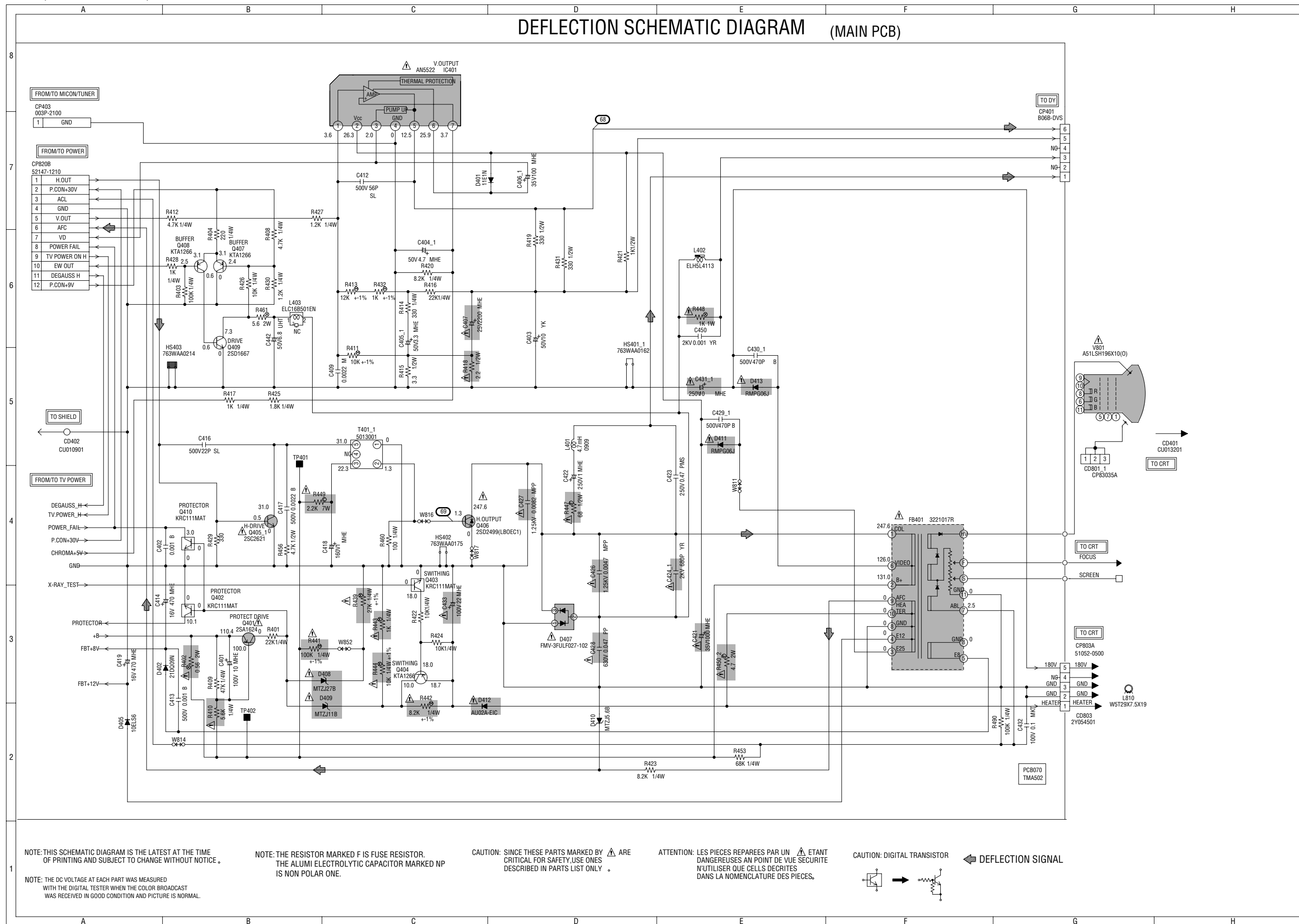

NOTE: THIS SCHEMATIC DIAGRAM IS THE LATEST AT THE TIME OF PRINTING AND SUBJECT TO CHANGE WITHOUT NOTICE.

NOTE: THE DC VOLTAGE AT EACH PART WAS MEASURED WITH THE DIGITAL TESTER WHEN THE COLOR BROADCAST WAS RECEIVED IN GOOD CONDITION AND PICTURE IS NORMAL.

NOTE: THE RESISTOR MARKED F IS FUSE RESISTOR. THE ALUMI ELECTROLYTIC CAPACITOR MARKED NP IS NON POLAR ONE.

CAUTION: SINCE THESE PARTS MARKED BY Δ ARE CRITICAL FOR SAFETY, USE ONES DESCRIBED IN PARTS LIST ONLY.

ATTENTION: LES PIECES REPARÉES PAR UN Δ ÉTANT DANGEREUSES AN POINT DE VUE SECURITE N'UTILISER QUE CELLS DECRITES DANS LA NOMENCLATURE DES PIECES.

CAUTION: DIGITAL TRANSISTOR \Rightarrow DEFLECTION SIGNAL

[CRT PWB CIRCUIT DIAGRAM]

CRT SCHEMATIC DIAGRAM (CRT PCB)

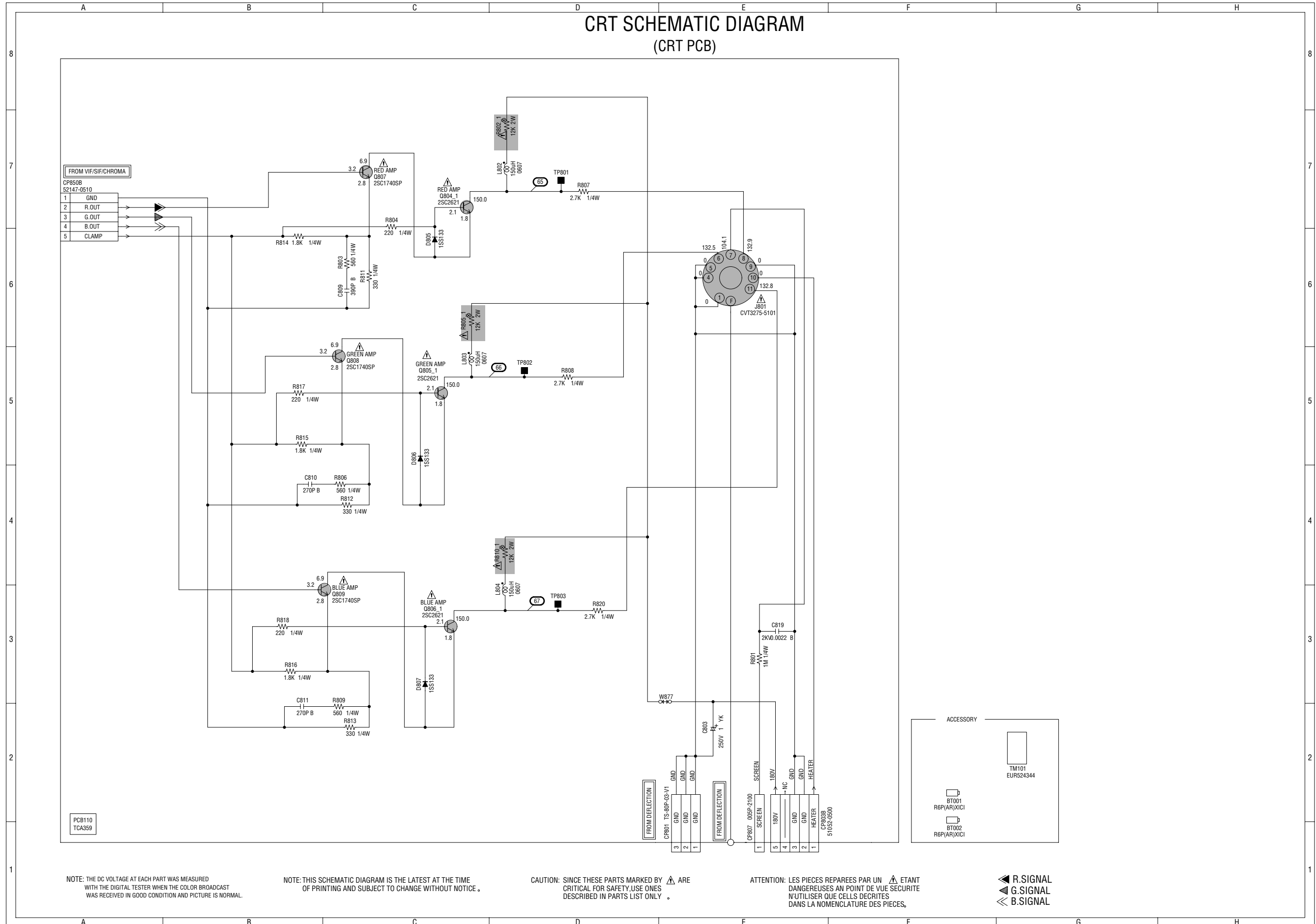

NOTE: THE DC VOLTAGE AT EACH PART WAS MEASURED WITH THE DIGITAL TESTER WHEN THE COLOR BROADCAST WAS RECEIVED IN GOOD CONDITION AND PICTURE IS NORMAL.

NOTE: THIS SCHEMATIC DIAGRAM IS THE LATEST AT THE TIME OF PRINTING AND SUBJECT TO CHANGE WITHOUT NOTICE.

CAUTION: SINCE THESE PARTS MARKED BY Δ ARE CRITICAL FOR SAFETY, USE ONES DESCRIBED IN PARTS LIST ONLY.

ATTENTION: LES PIÈCES RÉPARÉES PAR UN Δ ÉTANT DANGEREUSES AN POINT DE VUE SÉCURITÉ, N'UTILISER QUE CELLES DÉCRITES DANS LA NOMENCLATURE DES PIÈCES.

◀ R.SIGNAL
◀ G.SIGNAL
◀ B.SIGNAL

ACCESSORY

- TM101 EUR524344
- BT001 R6P(AR)XICI
- BT002 R6P(AR)XICI

PATTERN DIAGRAMS
[SYSCON PWB PATTERN]

(TOP SIDE)

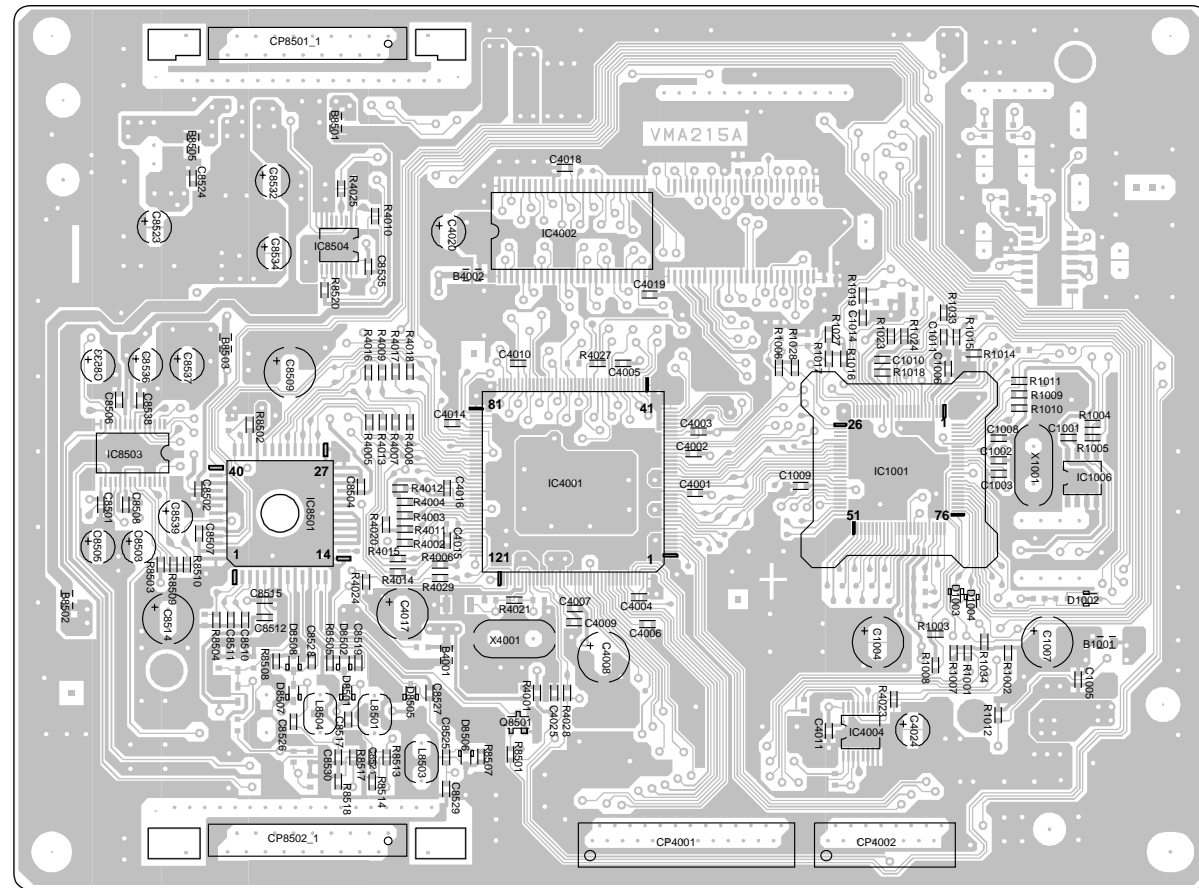

(BOTTOM SIDE)

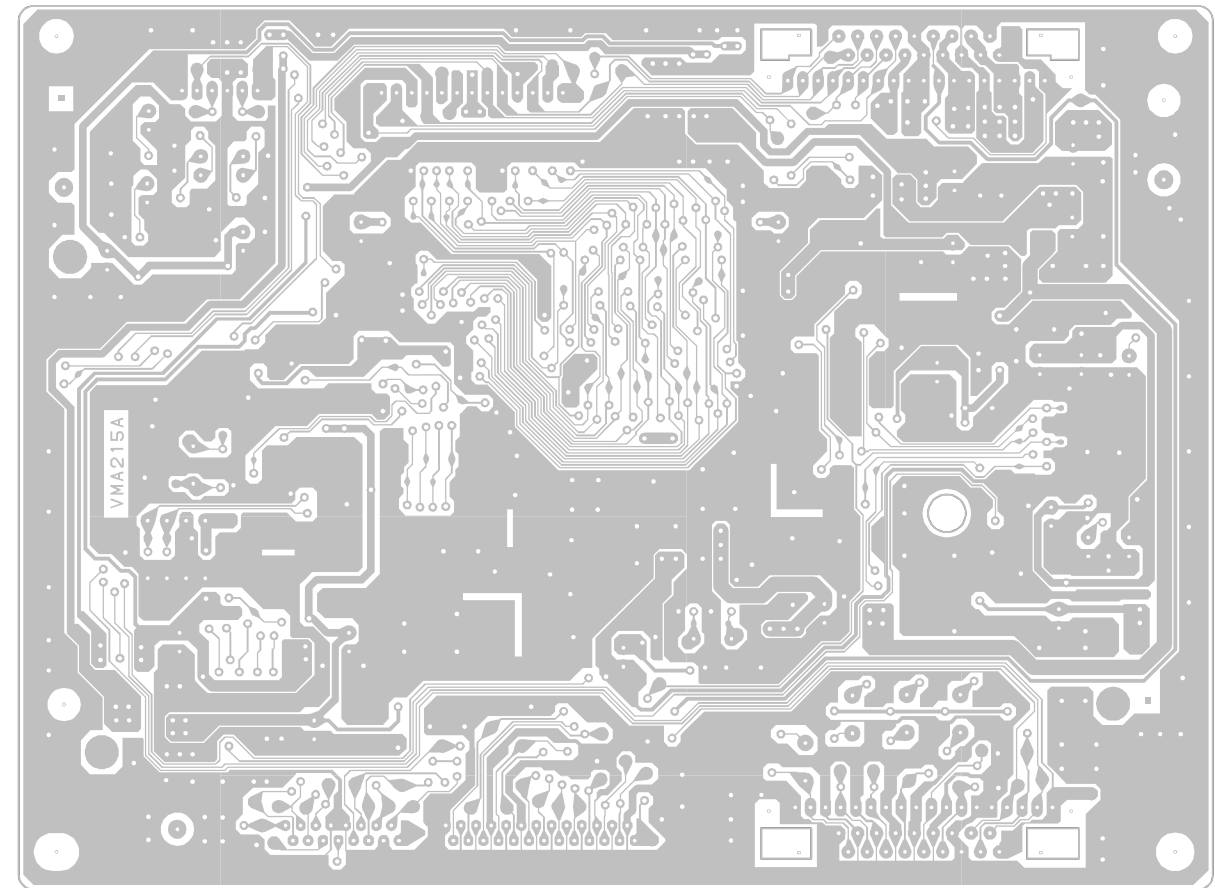

[AV PWB PATTERN(INSERTED PARTS)]

SOLDER SIDE

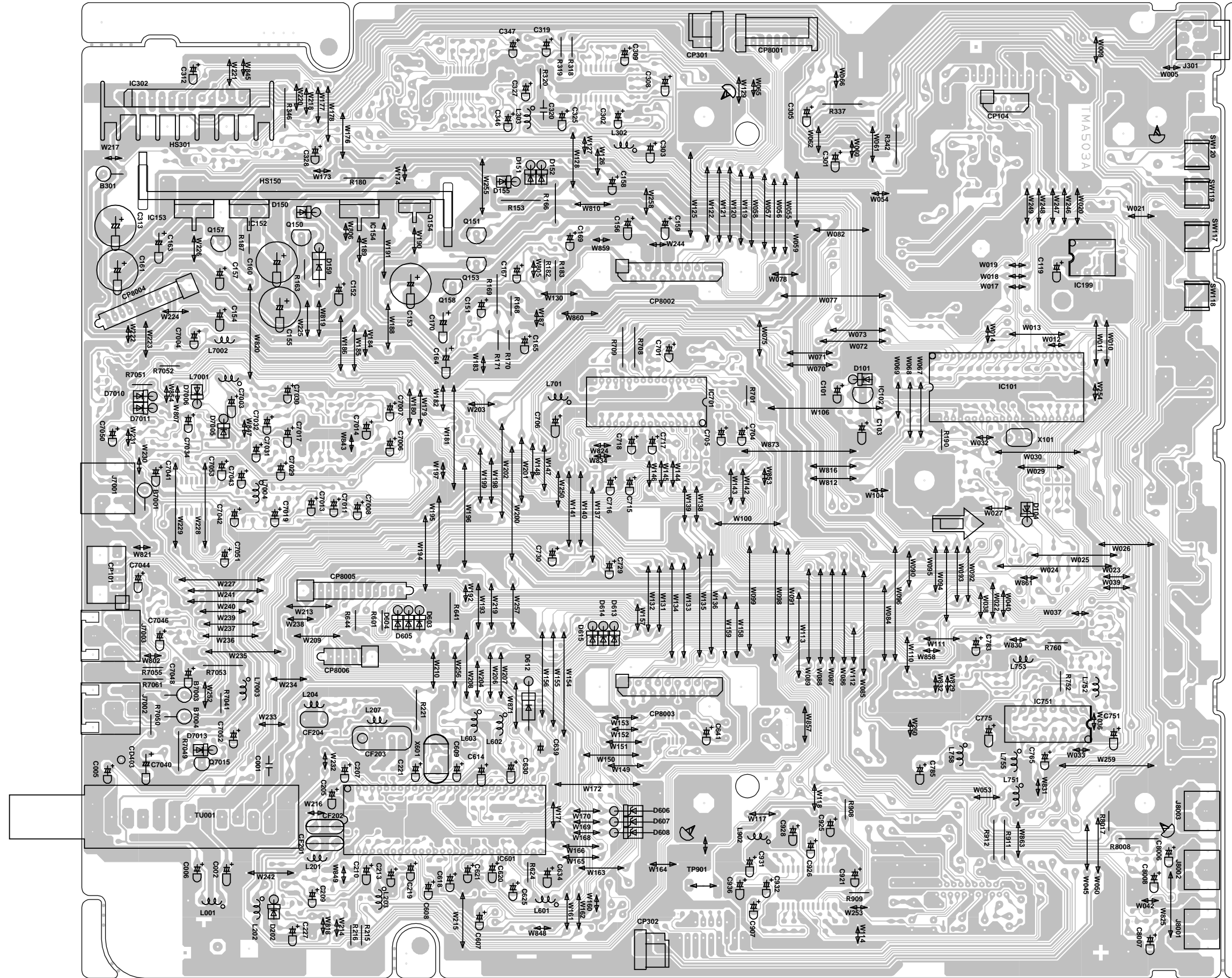

[AV PWB PATTERN(CHIP MOUNTED PARTS)]

SOLDER SIDE

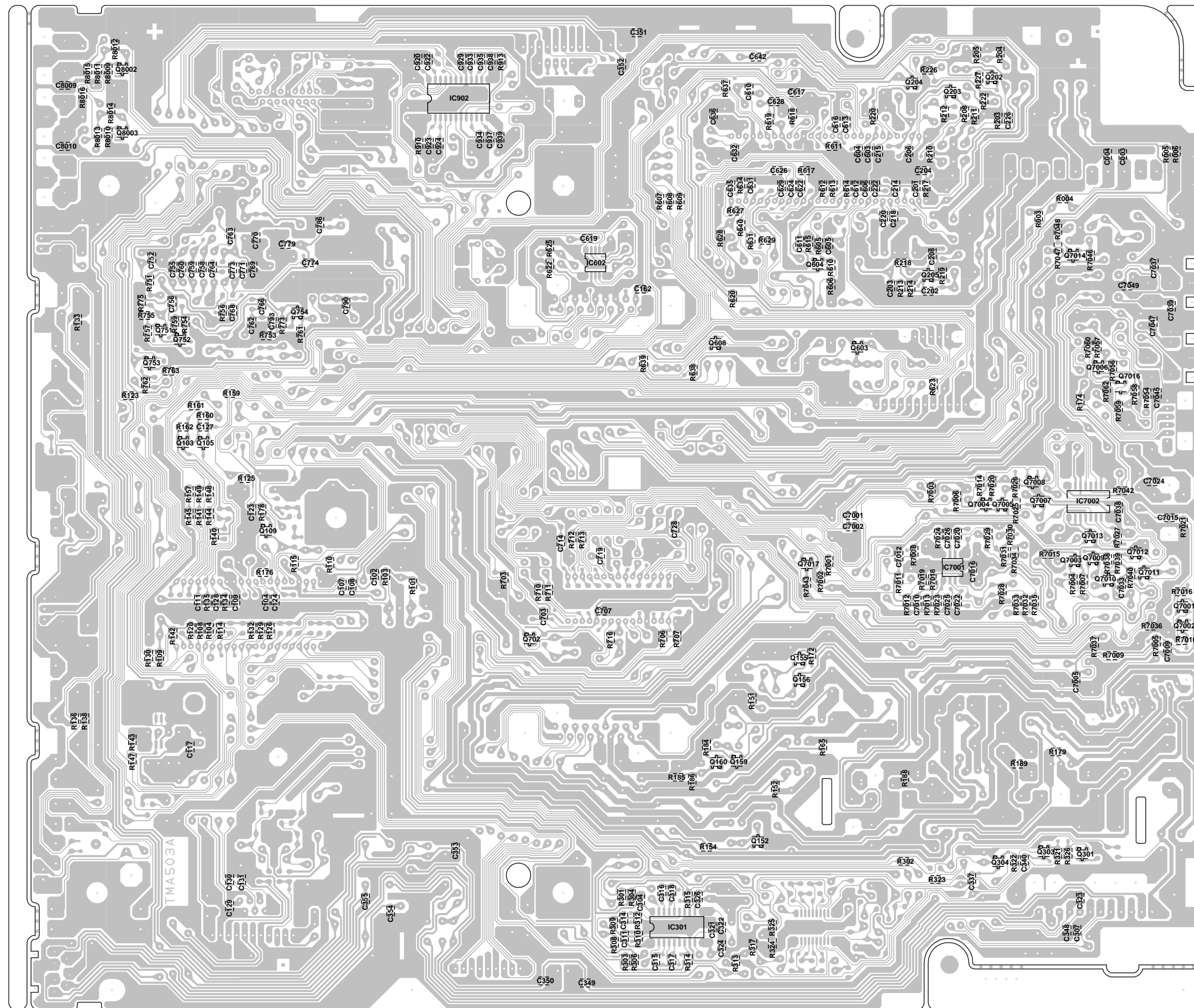

[MAIN/CRT PWB PATTERN]

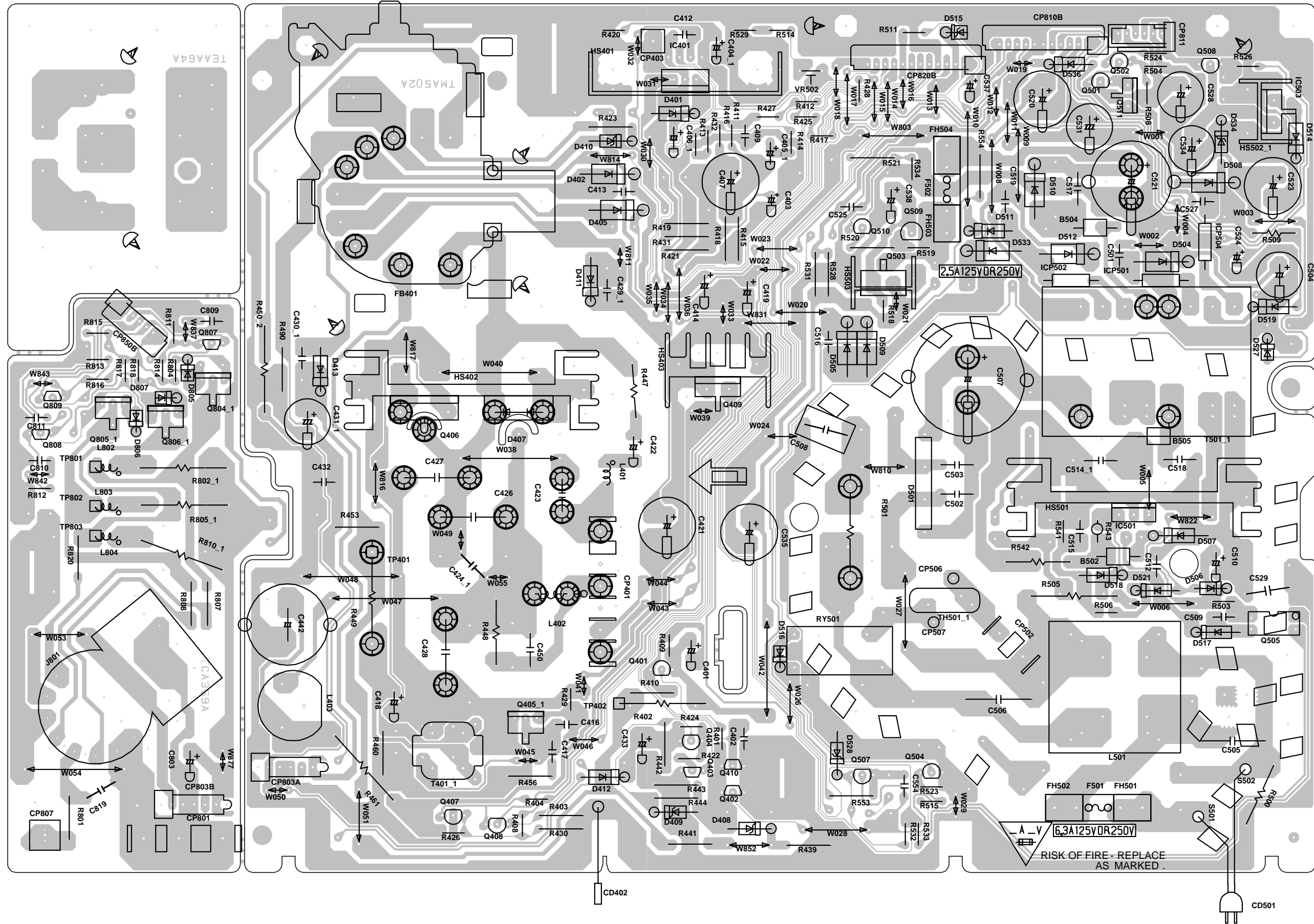

RISK OF FIRE - REPLACE AS MARKED.

[OPERATION PWB PATTERN]

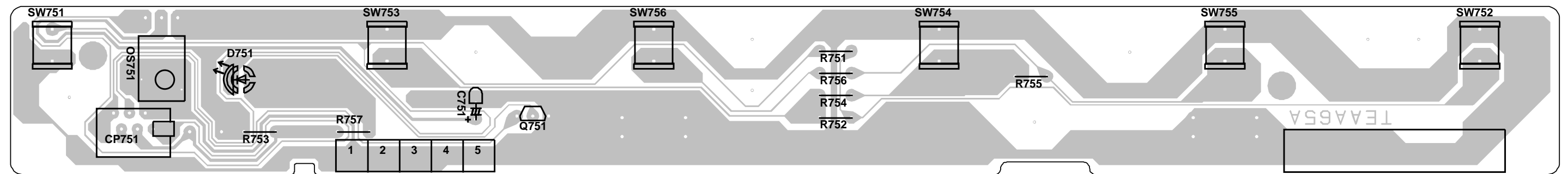

WAVEFORMS

MPEG

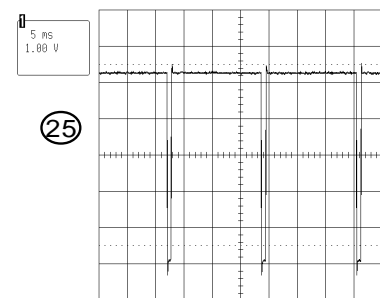
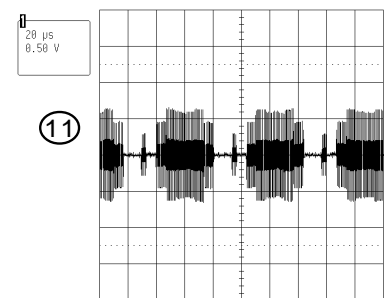
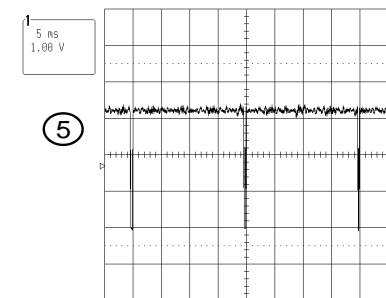
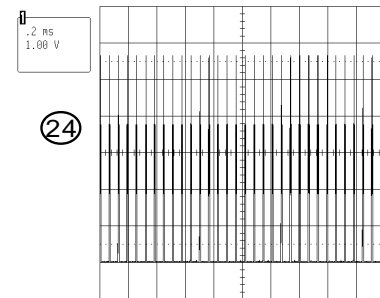
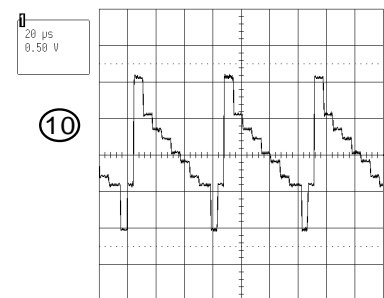
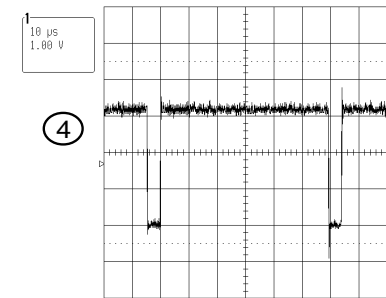
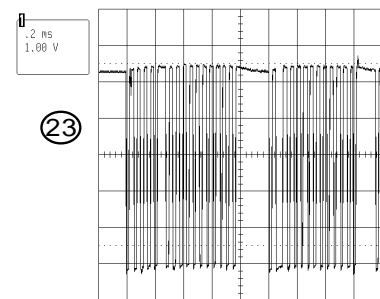
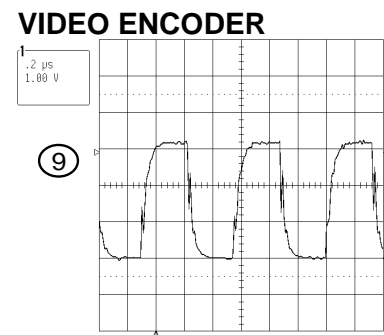
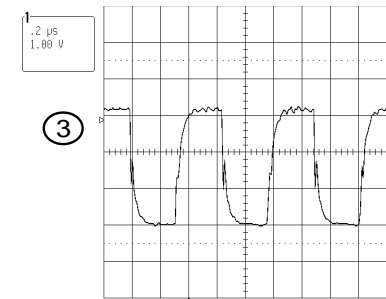
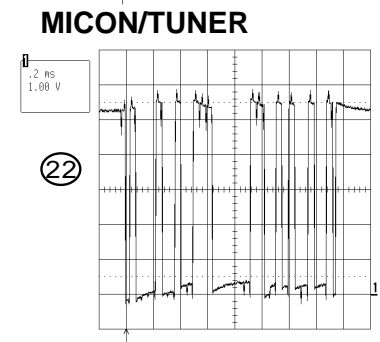
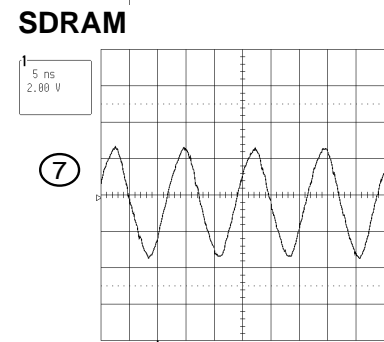
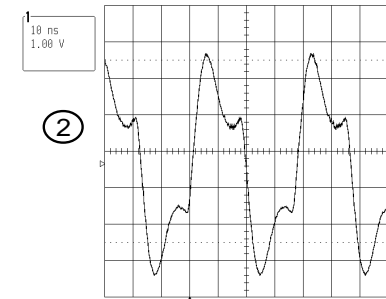
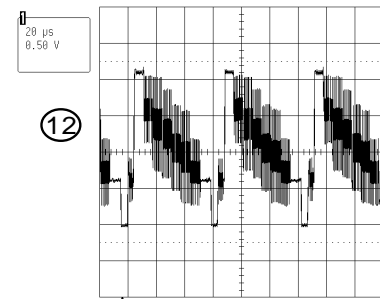
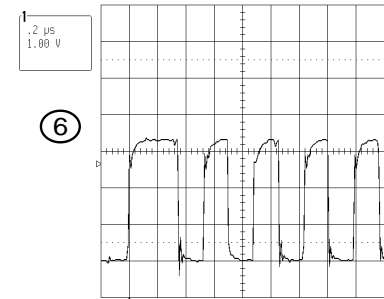
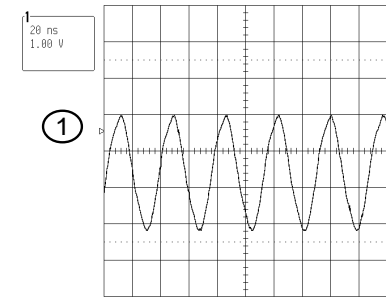

SDRAM

MICON/TUNER

VIF/SIF/CHROMA

SOUND AMP

IN/OUT

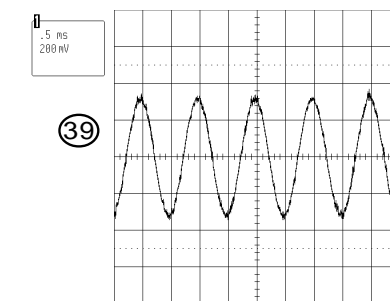
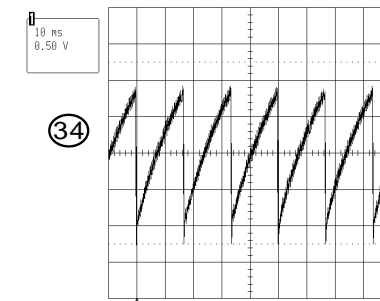
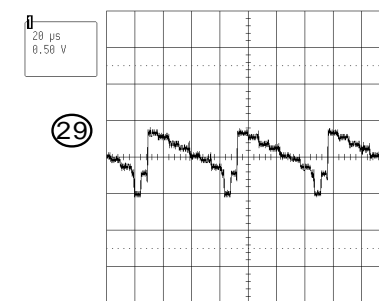
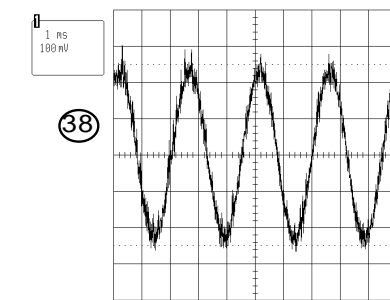
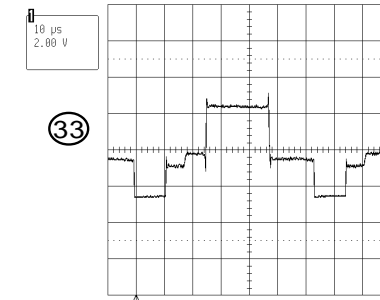
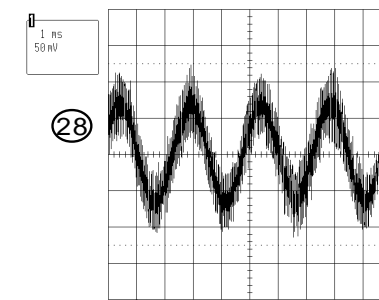
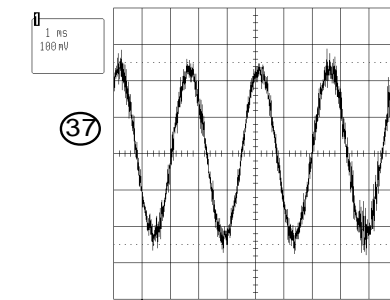
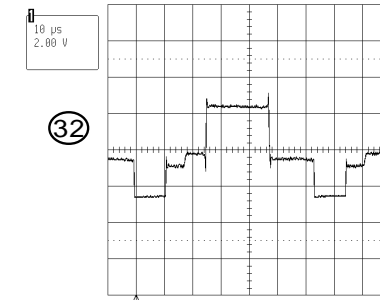
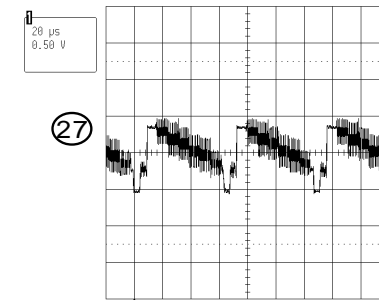
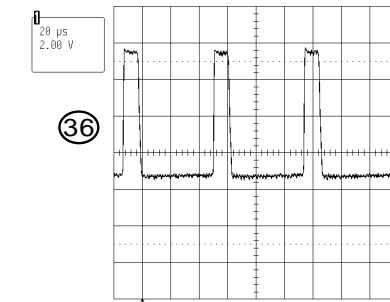
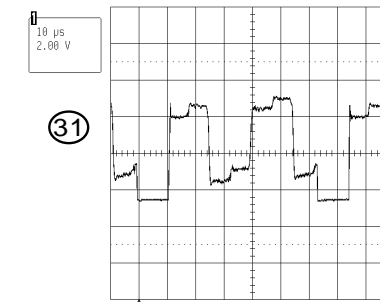
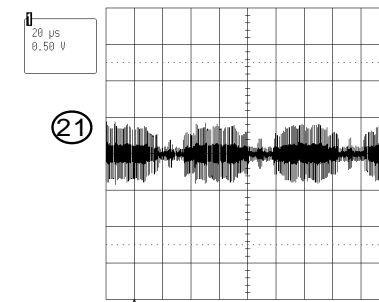
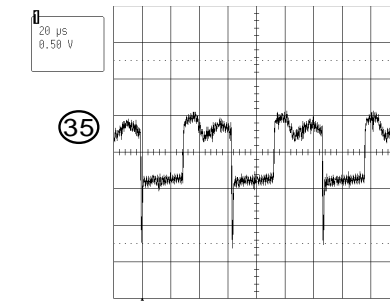
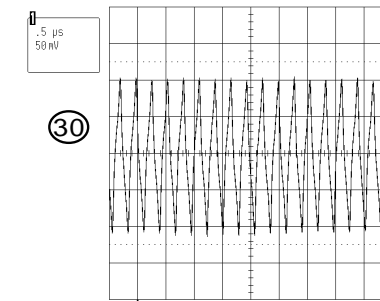
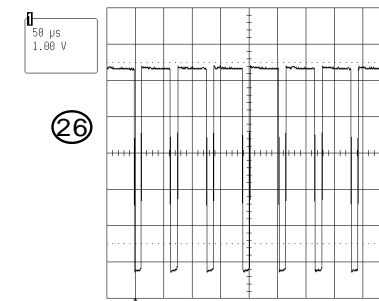

NOTE: The following waveforms were measured at the point of the corresponding balloon number in the schematic diagram.

NOTE: The following waveforms were measured at the point of the corresponding balloon number in the schematic diagram.

JVC SERVICE & ENGINEERING COMPANY OF AMERICA

DIVISION OF JVC AMERICAS CORP.

Head office :	1700 Valley Road, Wayne, New Jersey 07470	(973)315-5000
East Coast :	10 New Maple Avenue, Pine Brook, New Jersey 07058	(973)396-1000
Midwest :	705 Enterprise St. Aurora, Illinois 60504	(630)851-7855
West Coast :	5665 Corporate Avenue, Cypress, California 90630	(714)229-8011
Southwest :	10700 Hammerly, Suite 105, Houston, Texas 77043	(713)935-9331
Hawaii :	2969 Mapunapuna Place, Honolulu, Hawaii 96819	(808)833-5828
Southeast :	1500 Lakes Parkway, Lawrenceville, Georgia 30243	(770)339-2582

JVC CANADA INC.

Head office :	21 Finchdene Square Scarborough, Ontario M1X 1A7	(416)293-1311
Vancouver :	13040 Worster Court Richmond B.C. V6V 2B3	(604)270-1311

JVC